



18SP681 – EPA07 MBE 4000 Standard Grid Heater Relay Installation Instructions (P/N: A4601590004)

KIT DESCRIPTION

Kit P/N: A4601590004 includes a grid heater, relay, and bracket assembly for installation on EPA07 MBE 4000 vehicles currently equipped with a grid heater.

KIT CONTENTS

MBE 4000 Standard Grid Heater Relay Installation kit (P/N: A4601590004) contents listed in Table 1.

IMPORTANT!

EPA07 Engines currently equipped with a 3.6 kW grid heater (P/N: A0001592404) will require the provided 2.7 kW replacement grid heater (P/N: A0001595204) and updating the MCM software to the latest version available on the server. Failure to update the MCM software may cause various fault codes and premature relay failure.

Part No.	Qty.	Description
A4601530840	1	Relay Bracket
A0045459205	1	Relay
A9061500056	1	Jumper Harness
A0005455702	1	Bus Bar
N910105008042	4	M8x70 Bolt
N910105006002	2	M6x12 Bolt
A0001595204	1	2.7 kW Grid Heater
18SP681	1	Installation Instructions

Table 1 MBE 4000 Standard Grid Heater Relay Installation Kit (P/N: A4601590004)

INSTALLATION PROCEDURE

1. Make sure that the engine is off (key OFF, engine OFF).
2. Disconnect the batteries.
3. Disconnect the electrical harness connector and electrical cables from the grid heater. Note routing of electrical harness and cables for re-installation.
4. Remove mounting bolts securing the grid heater to the air intake elbow.
5. Remove the existing 3.6 kW grid heater from the engine.

6. Install relay bracket (P/N: A4601530840) and 2.7 kW grid heater (P/N: A0001595204) into the air intake elbow and fasten using new M8X70 bolts (P/N: N910105008042) as shown in Figure 1. Torque bolts to 25 N·m (18 lb·ft).
7. Mount the relay (P/N: A0045459205) to the relay bracket (P/N: A4601530840) using supplied M6x12 bolts (P/N: N910105006002). Torque fasteners to 15 N·m (11 lb·ft).

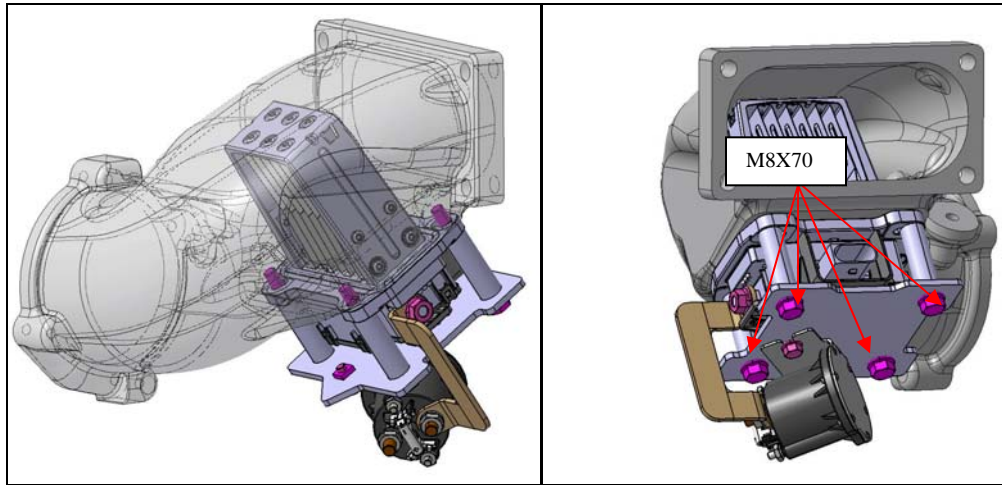

Figure 1 – Relay and Bracket Assembled to Air Intake Elbow

8. Connect the supplied electrical jumper harness (P/N: A9061500056) in series between the existing engine electrical harness and the grid heater.
9. Attach the relay signal wires from the electrical jumper harness to the relay terminals as shown in Figure 2. Torque fasteners to 2 N·m (15 lb·in.).

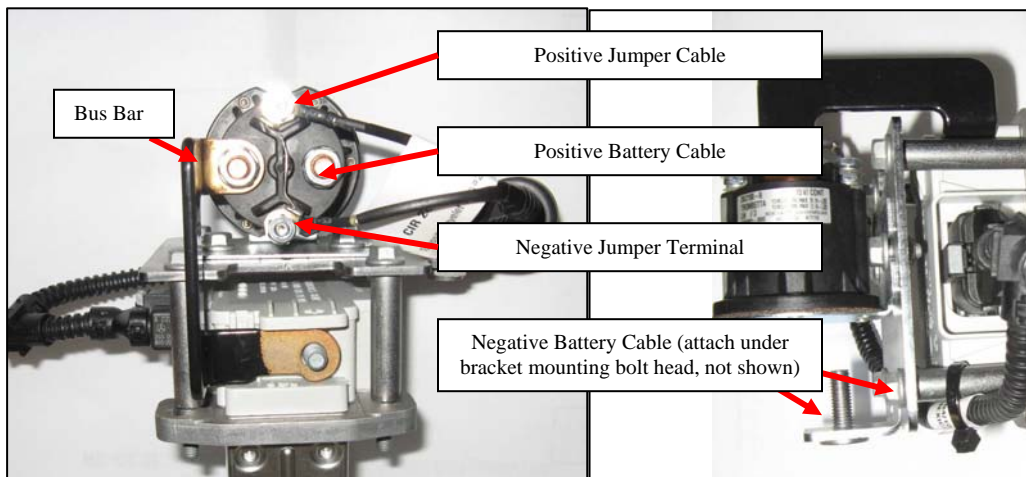
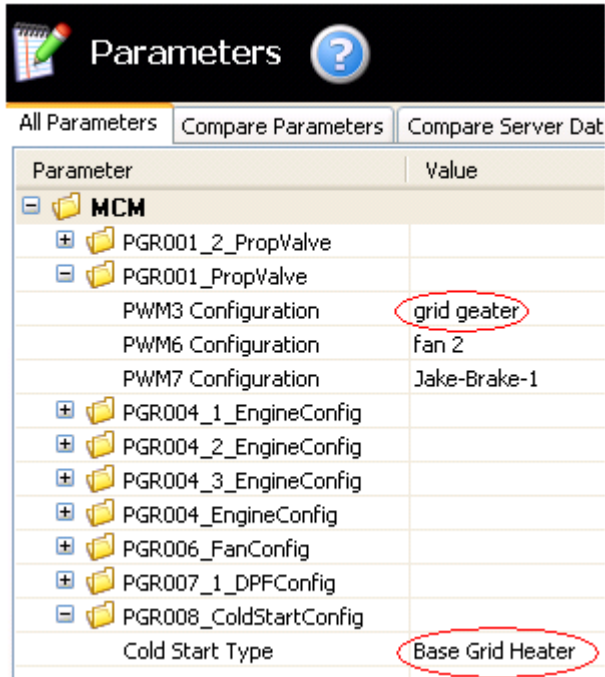

Figure 2 – Grid Heater Relay Wiring

10. Connect the positive battery cable to the relay terminal as shown in Figure 2. Torque nut to 4 N·m (35 lb·in.).
11. Attach the bus bar (P/N: A0005455702) from the terminal of the relay to the positive stud of the grid heater as shown in Figure 2. Torque relay nut to 4 N·m (35 lb·in.); torque grid heater nut to a maximum 25 N·m (18 lb·ft).
12. Connect the negative battery cable to the relay bracket stud (or under one of the bracket mounting bolt heads, depending on original configuration). Torque nut to 15-18 N·m (11-13 lb·ft).

Note: Route and secure the electrical cables similar to OEM configuration. Ensure no wires are rubbing on the bus bar.

13. Reconnect the batteries.
14. Apply protective dielectric coating to all electrical cable connections using 3M 1602 Insulating Enamel (or equivalent).
15. Reprogram the MCM with the latest software in DDRS. Verify the correct parameters have been changed; see Figure 3.



Parameter	Value	
MCM		
+	PGR001_2_PropValve	
-	PGR001_PropValve	
	PWM3 Configuration	grid geater
	PWM6 Configuration	fan 2
	PWM7 Configuration	Jake-Brake-1
+	PGR004_1_EngineConfig	
+	PGR004_2_EngineConfig	
+	PGR004_3_EngineConfig	
+	PGR004_EngineConfig	
+	PGR006_FanConfig	
+	PGR007_1_DPFConfig	
-	PGR008_ColdStartConfig	
	Cold Start Type	Base Grid Heater

Figure 3 Parameter change verification

Verifying Proper Operation of the Grid Heater and Relay Assembly

Once the hardware has been installed to the engine, care must be taken to ensure that the grid heater and relay function properly. Activating the grid heater using DDRS for more than two seconds will result in a fault code and will disable the grid heater.

With the correct grid heater installed and the MCM programmed, the grid heater should energize and stay on continuously (not cycle) during the following verification test. If the relay is audibly heard cycling, verify that the MCM has been programmed with the latest version of software, available on the server. See Figure 3. Reprogramming will correctly parameterize the MCM for the 2.7 kW grid heater.

Verification requires that the ambient air temperature be simulated to a very low value in order to activate the grid heater. Either an Instrument Gauge Tester or a 20k Ohm resistor must be used to simulate this low ambient temperature.

1. Ensure engine coolant temperature is 70° C (160° F) or lower before proceeding.
2. Disconnect the intake manifold pressure/temperature sensor.

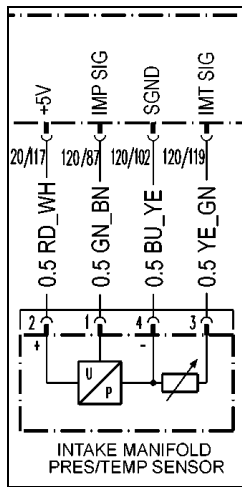

Figure 4 – Intake Manifold Pressure/Temperature Sensor Schematic

- Using Connector Test Kit J-48476, install the brown male blade terminals J-48476-25 to pins 3 and 4 of the harness side intake manifold pressure/temperature sensor connector.

Note: Exercise care when installing the blade terminals to the connector to avoid spreading or damaging the connector terminals.

- Install a 20k ohm resistor between the two blade terminals. An Instrument Gauge Tester (commercially available) set to the appropriate resistance may be utilized in place of a 20k ohm resistor.

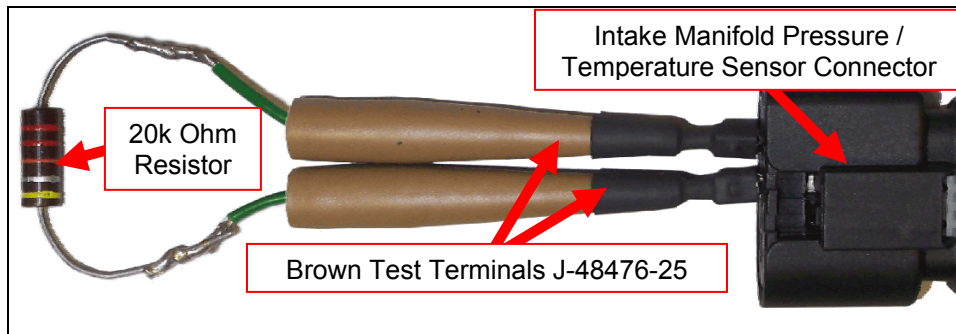
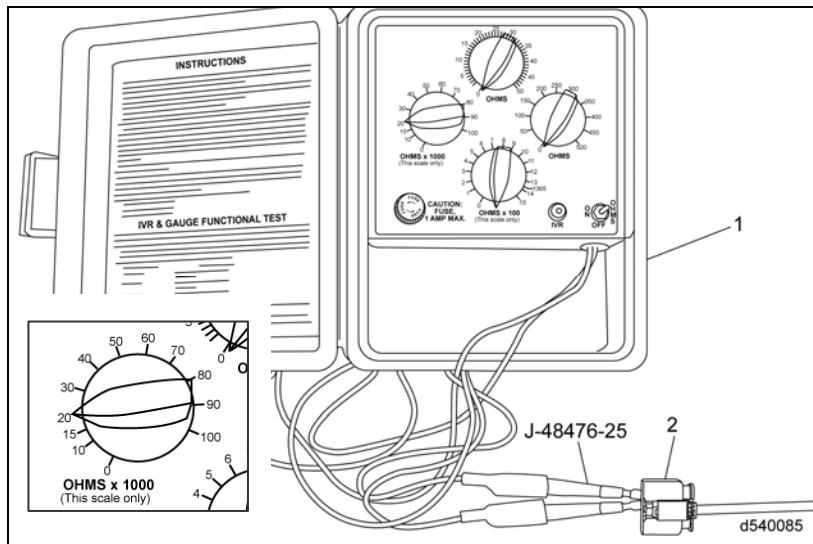

Figure 5 – 20k Ohm Resistor with J-48476-25 Plugged into Wiring Harness Connector



1. Instrument Gauge Tester 2. Inlet Manifold Pressure/Temperature Sensor Connector

Figure 6 – Instrument Gauge Tester set to 20k Ohms with J-48476-25 Terminals Plugged into Wiring Harness Connector

5. Connect DDRS 7.X (EPA07) or DDRS 6.X (EPA04) to the vehicle.
6. Turn the ignition ON and monitor the voltage on the positive stud of the grid heater using a voltmeter. The voltmeter should display battery voltage when the grid heater is activated. If the relay is cycling on and off, ensure the MCM was reprogrammed correctly.

Note: A fault code for the intake manifold pressure sensor will be active with the sensor unplugged.

7. The assembly is operating properly when the voltage check is verified and the vehicle does not set any fault codes for the grid heater.

Note: If the vehicle sets a fault code for the grid heater, ensure the MCM is programmed correctly and that all connections have been made according to the provided instructions, otherwise refer to the proper troubleshooting for the fault code.

POST INSTALLATION TROUBLESHOOTING DIAGNOSTICS		
Symptoms or Code(s)	Possible Cause / (Solution)	Additional Notes:
Relay Clicks On and Off rapidly at ~ 3 - 4 Hz when enabled	Wrong Grid Heater parameterization. (Re-Flash MCM with latest software in step 16).	"Exporting before" and then "Importing parameters after" a MCM re-flash can cause this issue.
729/7 GH Defect; GH Not Enabled	Typically because polarity of relay control jumper cable is reversed or not connected. (Verify Steps 9 & 10).	See Figure 2 for proper jumper terminal polarity or Relay Control Jumper Cable.
698/4 GH Circuit Failed Low; GH Not Enabled	HSW1 of jumper cable at MCM or Grid heater is open circuit. (Verify control jumper connections; Review Steps 9 & 10)	Relay Control Jumper Cable p/n: A9061500056 may be defective.
45/12 – Grid Heater Defect	Typically a programming issue.	Reflash the PLD using the Replace PLD button in MBE Reprogramming System.

8. Turn ignition off.
9. Remove the Connector Test Kit terminals and resistor.
10. Reconnect the intake manifold pressure/temperature sensor.
11. Clear accompanying fault code(s) and release vehicle.



13400 Outer Drive, West, Detroit, Michigan 48239-4001
Telephone: 313-592-5000
www.detroitdiesel.com

Specifications are subject to change without notice. Detroit Diesel Corporation is registered to ISO 9001:2001.
Copyright © 2011 Detroit Diesel Corporation. All rights reserved. Detroit Diesel Corporation is a Daimler company.

18SP681 1111 As technical advances continue, specifications will change. Printed in U.S.A