

## 18SP677 – DD Platform Bracket Stabilizer Kit for Tensioner Bracket

### KIT DESCRIPTION

Service kit contains all the necessary parts to install the bracket stabilizer for the tensioner bracket on all DD Platform engines.

### KIT CONTENTS

Service kit contains the parts listed in Table 1:

Part No.	Qty.	Description
A4712020840	1	Bracket
N910105010007	1	Hex Head Flange Bolt, M10 x 35
N000000005542	1	Hex Head Screw, M16 x 1.5 x 50
18SP677	1	Installation Instructions

**Table 1 DD Platform Bracket Stabilizer Kit Contents**

See Figure 1 for kit components.

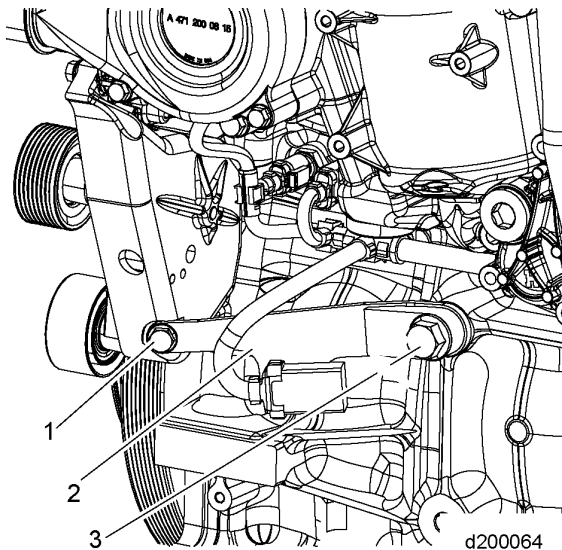

1. Bolt, M10 x 35 (P/N: N910105010007)
2. Bracket (P/N: A4712020840)
3. Bolt, M16 x 1.5 x 50 (P/N: N000000005542)

**Figure 1 Bracket Stabilizer Kit**

## **INSTALL PROCEDURE**

Use the following procedure to install the stabilizer bracket for the tensioner:

1. Install bracket A4712020840, hex head flange bolt N910105010007, and hex head screw N000000005542 as shown in Figure 1.
2. Tighten both bolts by hand.
3. Torque bolt N910105010007 to 60 N·m (44 lb·ft) and mark with an “X” on the head of the bolt.
4. Torque bolt N000000005542 to 250 N·m (184 lb·ft) and mark with an “X” on the head of the bolt.
5. Install 10-pin connector as shown above for D471914 (fire truck only). D471917 (coach) connector is installed at DDC.

<b>NOTICE:</b>
The tensioner bracket will fail if the fasteners are NOT properly torqued.



13400 Outer Drive, West, Detroit, Michigan 48239-4001  
Telephone: 313-592-5000  
www.detroitdiesel.com

---

Specifications are subject to change without notice. Detroit Diesel Corporation is registered to ISO 9001:2001.  
Copyright © 2011 Detroit Diesel Corporation. All rights reserved. Detroit Diesel Corporation is a Daimler company.

18SP677 1102 **As technical advances continue, specifications will change. Printed in U.S.A.**