



18SP644* – Series 60[®] Marine Exhaust Manifold Service Kit P/N: E23535159

* Revision - 10/12/09

KIT DESCRIPTION

Service kit (P/N: E23535159) contains an improved design for the exhaust manifold, thermostat housing spacer, and all related parts to address possible coolant flow issues at ports #1, #2, #3 and the exhaust turbocharger flange of the former exhaust manifold. See Figure 1. The improved exhaust manifold design now uses two outlet tubes that connect to the thermostat housing: the existing tube located between exhaust ports #3 and #4 has been reduced in diameter corresponding to 1/3 of the current flow and a second tube with a diameter corresponding to 2/3 of the current flow has been added between ports #1 and #2. The new thermostat housing spacer design also has the two hose fittings. A boss at the turbo flange has been added to the new exhaust manifold for the attachment of a vent line that routes to the thermostat housing.

KIT CONTENTS

The new service kit contains the following parts listed in Table 1.

Level	Part Number	Quantity	Description
1	23537770	1	Marine Exhaust Manifold
1	23507438	4	Stud, M10 x 1.5
1	08924140	1	Cock, Drain ¼ NPTF
1	23525090	3	Gasket, Exhaust Manifold
1	11506101	4	Nut, M10 x 1.5
1	08929169	4	Washer
1	08929529	1	Gasket, Turbocharger
1	08929764	1	Hose, 0.75 x 3.50
1	05186840	2	Clamp, Hose 1.0" – 1.50" ID
1	23535170	1	Hose, 1/18" x 3.25
1	08929756	2	Clamp, Hose 15/16" – 1-1/4" ID
1	23525151	2	Gasket, Thermostat Housing
1	23535127	1	Thermostat Housing Spacer Assembly
1	08924517	1	Plug Pipe, 3/8 – 18-7/8 Taper Sq
1	23537804	1	Hose, #4 X 38.00

1	02488022	1	Clip, Hose 0.562 DIA 3/8 Bolt
1	08924147	1	Fitting, Straight ¼ FLDTUB 1/8 NPTF
1	23537818	1	Fitting, T Male 7/16 FLDTUB ¼ NPTF
1	11504986	1	Bolt, M8 1.25 X 14.0
1	18SP644Rev	1	Installation Instructions

Table 1 S60 Marine Exhaust Manifold Service Kit Contents (P/N: E23535159)

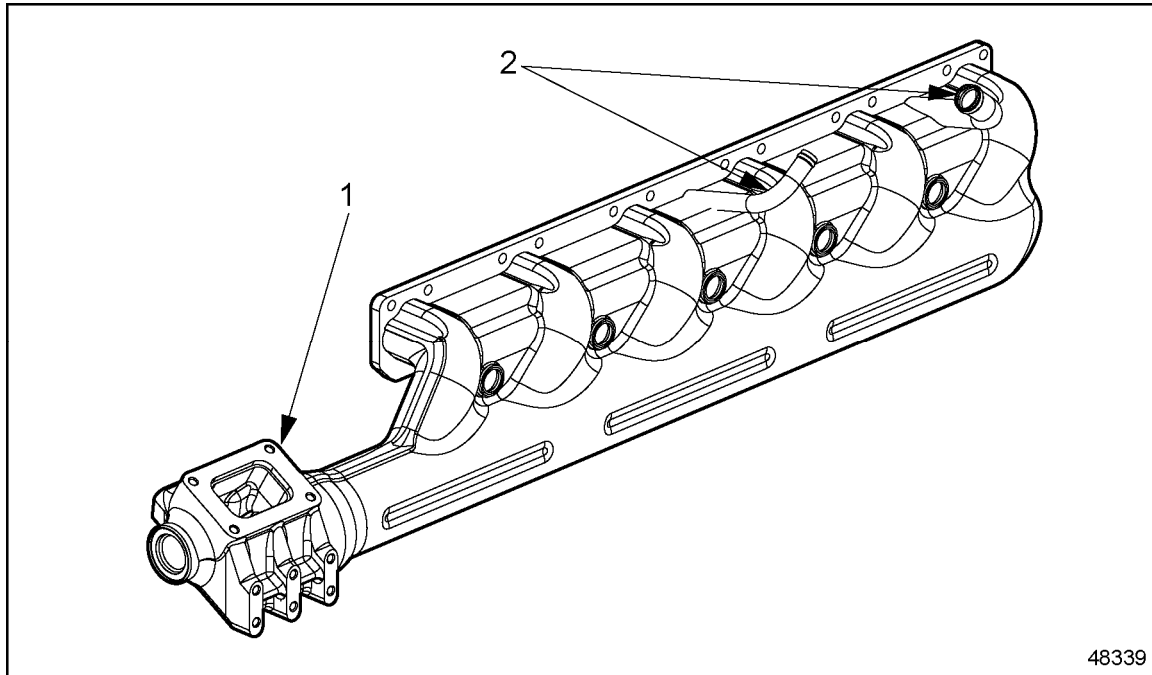

- 1. Vent Boss
- 2. Outlet Tubes

Figure 1 Improved S60 Marine Exhaust Manifold (P/N: 23537770)

INSTALLATION PROCEDURE

Install the improved exhaust manifold and thermostat housing spacer as follows (see Figures 2, 3 and 4):

1. Install the new exhaust manifold gaskets (P/N: 23525090) and the improved exhaust manifold (P/N: 23537770).
2. Install the new hoses (P/N: 23535170, P/N: 08929764) and clamps (P/N: 08929756, P/N: 05186840) to the corresponding exhaust manifold outlet tubes.

NOTE:
Use soapy water to install the hoses on the hose fittings.

NOTE:

If P/N: 23535170 Hose (1-1/8 x 3-1/4), is supplied as a 4.0 length; cut hose as necessary to fit between the spacer and exhaust manifold.

3. Install the plug (P/N: 08924517) onto the thermostat housing spacer.
4. Install the thermostat housing spacer assembly (P/N: 23535127) with two new gaskets (P/N: 23525151). Connect the upper ends of the hoses (P/N: 23535170, P/N: 08929764) and clamps (P/N: 08929756, P/N: 05186840) to the corresponding thermostat housing spacer hose fittings.
5. Install the straight fitting (P/N: 08924147) into the exhaust manifold turbocharger flange boss. Replace the elbow fitting in the top of the thermostat housing with the T-fitting (P/N: 23537818). Connect the vent hose (P/N: 23537804) to the two fittings. Route vent line using hose clip (P/N: 02488022) with bolt (P/N: 11504986) installed at the top right-rear corner of the engine head.
6. Install new M10 x 1.5 studs (P/N: 23507438) and turbocharger gasket (P/N: 08929529).
7. Use the new washers (P/N: 08929169) and M10 x 1.5 nuts (P/N: 11506101) to install the turbocharger.

NOTE:

To install the remaining components and to complete the installation of this service kit, refer to the *Series 60 Service Manual* (6SE483).

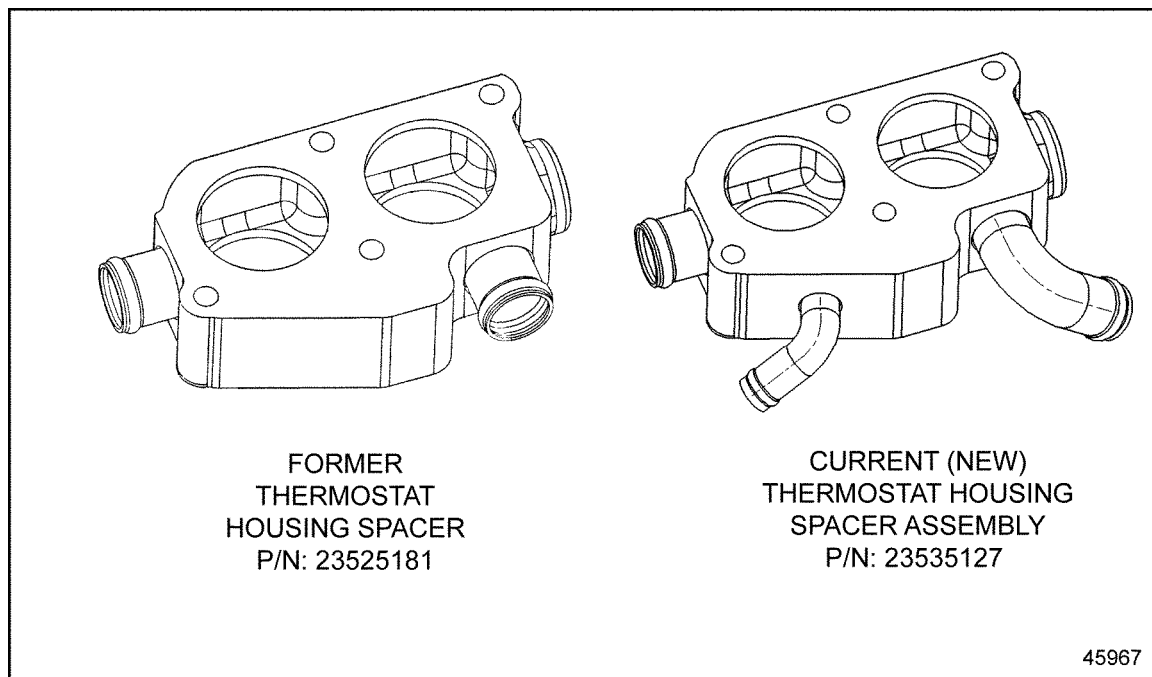
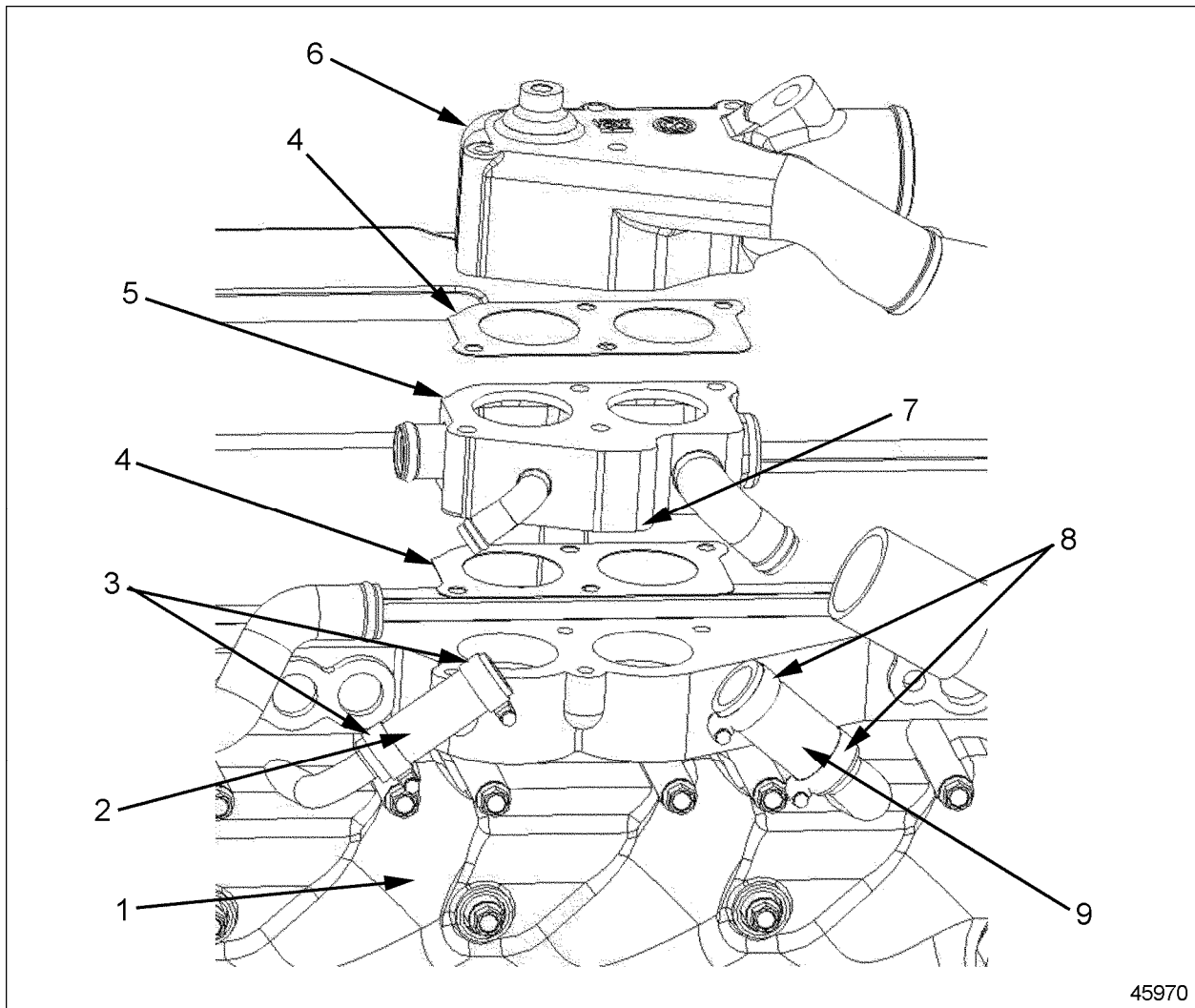

Figure 2 Former and Current S60 Marine Thermostat Housing Spacer



45970

- | | |
|---|--|
| 1. Exhaust Manifold (P/N: 23537770) | 6. Existing Thermostat Housing Assembly |
| 2. Hose, 3/4" x 3-1/2" (P/N: 08929764) | 7. Plug, 3/8 – 18-7/8 Taper (P/N: 08924517) |
| 3. Clamp, Hose, 15/16" to 1-1/4" ID (P/N: 08929756) | 8. Clamp, Hose, 1.0" to 1.50" ID (P/N: 05186840) |
| 4. Gasket (P/N: 23525151) | 9. Hose, 1-1/8" x 3-1/4" (P/N: 23535170) |
| 5. Thermostat Housing Spacer Assy. (P/N: 23535127) | |

NOTE: Not all kit parts are shown in Figures 3 & 4.

Figure 3 S60 Marine Exhaust Manifold Service Kit (P/N: E23535159)

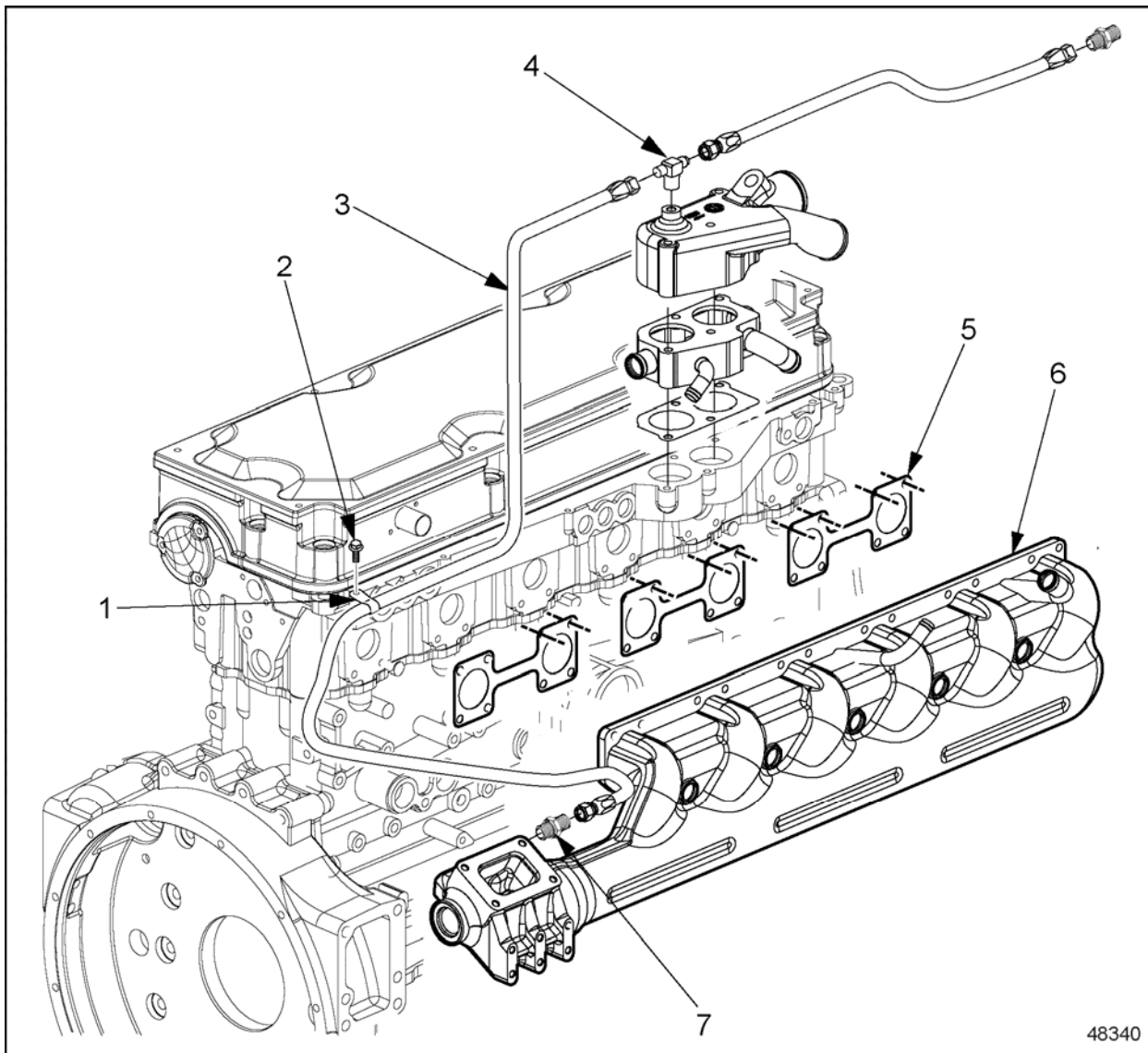

- | | |
|--|---|
| 1. Clip, Hose 0.562 DIA 3/8 Bolt (P/N: 02488022) | 5. Gasket, Exhaust Manifold (P/N: 23525090) |
| 2. Bolt, M8 1.25 x 14.0 (P/N: 11504986) | 6. Exhaust Manifold (P/N: 23537770) |
| 3. Hose, #4 x 38.00 (P/N: 23537804) | 7. Fitting, Straight (P/N: 08924147) |
| 4. Fitting, T Male (P/N: 23537818) | |

NOTE: Not all kit parts are shown in Figures 3 & 4.

Figure 4 S60 Marine Exhaust Manifold Service Kit (P/N: E23535159)



13400 Outer Drive, West, Detroit, Michigan 48239-4001
 Telephone: 313-592-5000
 www.detroitdiesel.com

Specifications are subject to change without notice. Detroit Diesel Corporation is registered to ISO 9001:2001. Copyright © 2009 Detroit Diesel Corporation. All rights reserved. Detroit Diesel Corporation is a Daimler company.

18SP644Rev. 0910 As technical advances continue, specifications will change. Printed in U.S.A.