



Installation Instructions

18SP605 – Series 60[®] Installation Instructions for the Turbocharger Oil Drain Kit on EGR Engines

Introduction

Detroit Diesel Corporation has a new oil drain kit for improved oil flow from the turbocharger on Series 60 engines. The kit is for use on model year 2002, 2003, and 2004 EGR engines.

The key feature of this kit is an increase in the turbocharger oil drain tube diameter, which will enhance flow.

The oil drain kit (P/N: 23535289) hardware is listed in Table 1.

New Part Number	Quantity	Description
23532213	1	Oil Drain Tube (mid-setback Turbo)
23532326	2	O-rings, Drain Tube
23532171	1	Oil Drain Adaptor
23550752	2	Bolts, Adaptor
08929285	1	Gasket, Turbo Oil Drain
18SP605	1	Installation Instructions

Table 1 Oil Drain Kit (P/N: 23535289) Components

Installation

Install the oil drain kit as follows:

1. Remove former oil drain tube and gasket.
2. Install the new drain tube (P/N: 23532213), oil drain adaptor, gasket, o-rings, and bolts supplied in the kit. See Figure 1.
3. Torque bolts to 30-38 N·m (22-28 lb·ft).

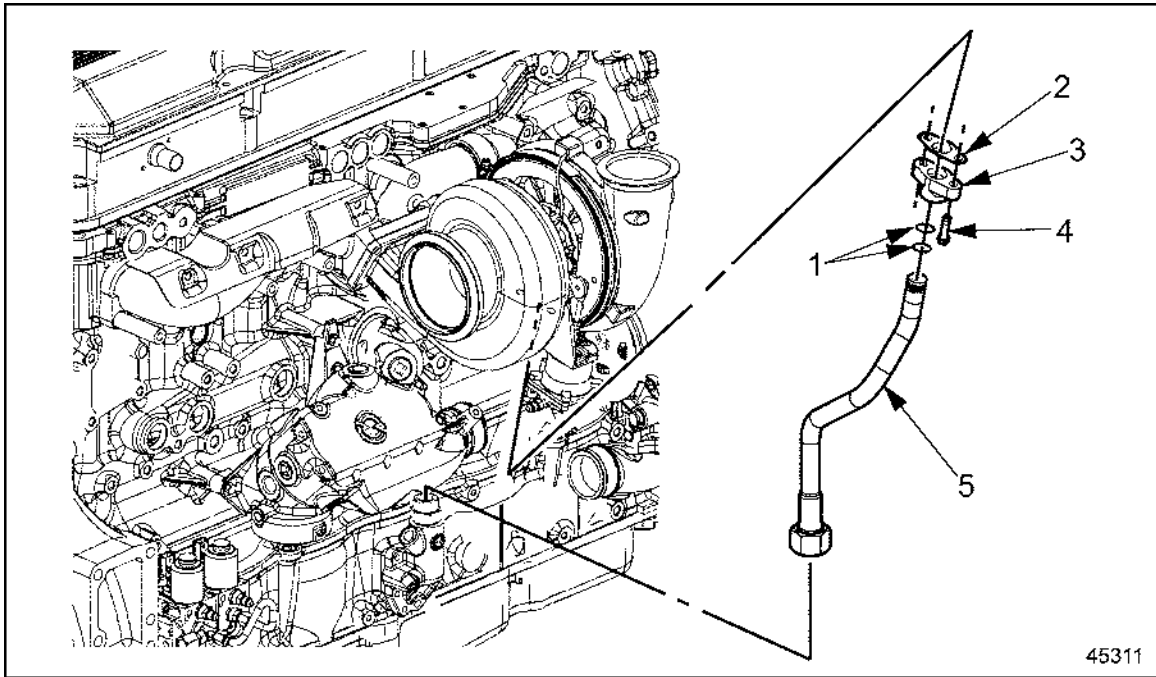

- 1. O-ring, P/N: 23532326
- 2. Gasket, P/N: 08929285
- 3. Adaptor, P/N: 23532171

- 4. Bolt, P/N: 23550752
- 5. Oil Drain Tube, P/N: 23532213

Figure 1 Installing New Oil Drain Tube

DETROIT DIESEL



13400 Outer Drive, West, Detroit, Michigan 48239-4001
 Telephone: 313-592-5000
www.detroitdiesel.com

Copyright© 2005 Detroit Diesel Corporation. Detroit Diesel®, DDC®, and the spinning arrows design are registered trademarks of Detroit Diesel Corporation. All other trademarks are the property of their respective owners.
18SP605 0502 As technical advances continue, specifications will change. All rights reserved. Printed in U.S.A.