



Installation Instructions

18SP596 – Series 60[®] Right-Side EGR Bolt-Together System to a Spherical Joint Tube-and-Shell Cooler with Hydraulic Actuator Valve

Introduction

There are two new kits for different orientations of the hot pipe assemblies with a hydraulic actuator valve. Table 1 shows the correct kit part number for its corresponding exhaust manifold type.

Kit Part No.	Description	
23534871	Mid-Setback Exhaust Manifold Center Section	Series 60 Hydraulic EGR Valve Service Kit
23534872	High-Mount Exhaust Manifold Center Section	Series 60 Hydraulic EGR Valve Service Kit

Table 1 Hydraulic Actuator Service Kits

Installation

NOTE:

The bellows assembly is a one-time use component. Once removed, the bellows must be replaced. Before assembly, ensure that the exhaust manifold center section is the correct type for engine. Two types, a high-mount and a mid-setback mount, are available.

NOTE:

This service kit should be installed only on engines with tube and shell EGR cooler, P/N: 23533179.

NOTE:

It may be helpful to spray penetrating oil on the nuts of the “U” bolt clamp holding the EGR valve to the EGR cooler and allow it to soak for a few minutes. This will facilitate the later removal of the “U” bolt clamp and reuse of the “T” bolt assemblies.

Pre-Assembly

Pre-assemble the exhaust center section manifold as follows:

1. Install two M8 studs into exhaust center section. Torque to 20-24 N·m (15-18 lb·ft). See Figure 8.

2. Thread four M10 turbo mounting studs into exhaust center section and torque to 20-24 N·m (15-18 lb·ft).
3. Install upper hot pipe gasket and upper hot pipe to exhaust center section manifold and torque nuts (M8 x 1.25) to 22-26 N·m (16-19 lb·ft). See Figure 8.

Exhaust Manifold Installation

Install the exhaust manifold as follows:

1. Ensure that the eight seal rings are installed in the four grooves on the exhaust manifold center section.
2. Ensure that the gaps on the sealing rings in each groove are 180 degrees from each other, and turn the set of rings in the neighboring groove 90 degrees so that the net effect is a gap every 90 degrees. See Figure 1.

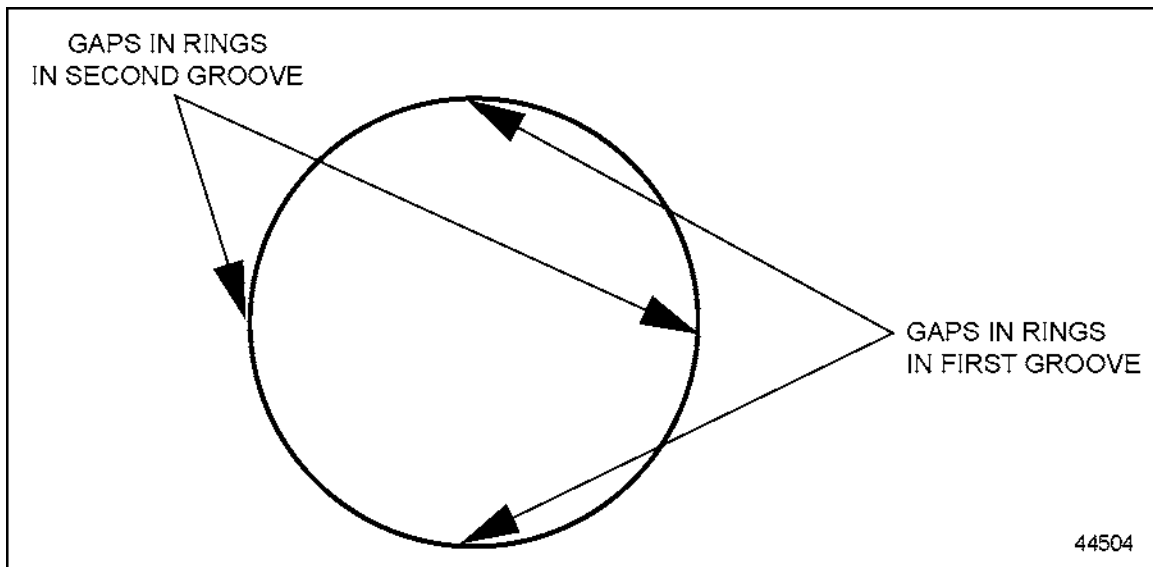

Figure 1 Sealing Ring Gap Location- Exhaust Manifold

3. Install six exhaust manifold guide studs, J 36107 (four guide studs per set), into the cylinder head in locations 6, 8, 4, 1, 9, and 11 to hold the three exhaust manifold gaskets in the correct position and facilitate manifold installation. See Figure 2.

NOTE:

The exhaust gasket can be positioned either way. Ensure the guide studs and gaskets are positioned correctly for the manifold being installed.

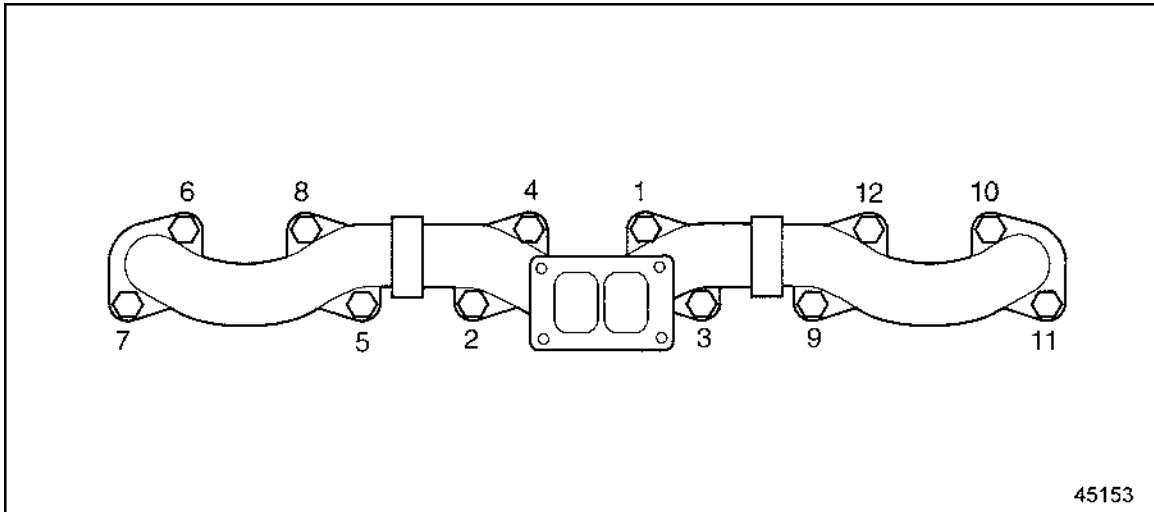

Figure 2 Torque Sequence for Exhaust Manifolds

4. Install the exhaust gaskets to the guide studs.
5. Install two end manifolds to the center manifold and install assembly on the guide studs.
6. Install and slightly tighten the mounting bolts and spacers in locations 7, 5, 2, 3, 12, and 10. The load should be enough to hold the exhaust manifold assembly in place when the guide studs are removed. See Figure 2.
7. Remove the guide studs, making sure the exhaust manifold has not moved.

NOTE:

If the manifolds move while removing the guide studs, loosen all bolts and repeat Step 6.

8. Install the remaining manifold bolts and spacers to the holes from which the studs were removed. Torque all bolts to 58-73 N·m (43-54 lb·ft) See Figure 2 for torque sequence.

Hydraulic Actuator-to-EGR Valve Assembly Installation

To assemble the hydraulic valve assembly, perform the following steps before installing this assembly to the bellows: (See Figure 3.)

1. Remove the old EGR valve assembly from the engine. This will not be reused.
2. Remove the reusable hydraulic actuator, P/N: 23533139, from the old EGR valve.
3. Remove heat shields and discard only shield P/N: 23529735.
4. Attach the hydraulic actuator to the EGR valve assembly using a new shield, P/N: 23529735, and tighten bolts, P/N: 11509515, to 30-35 N·m (22-26 lb·ft).

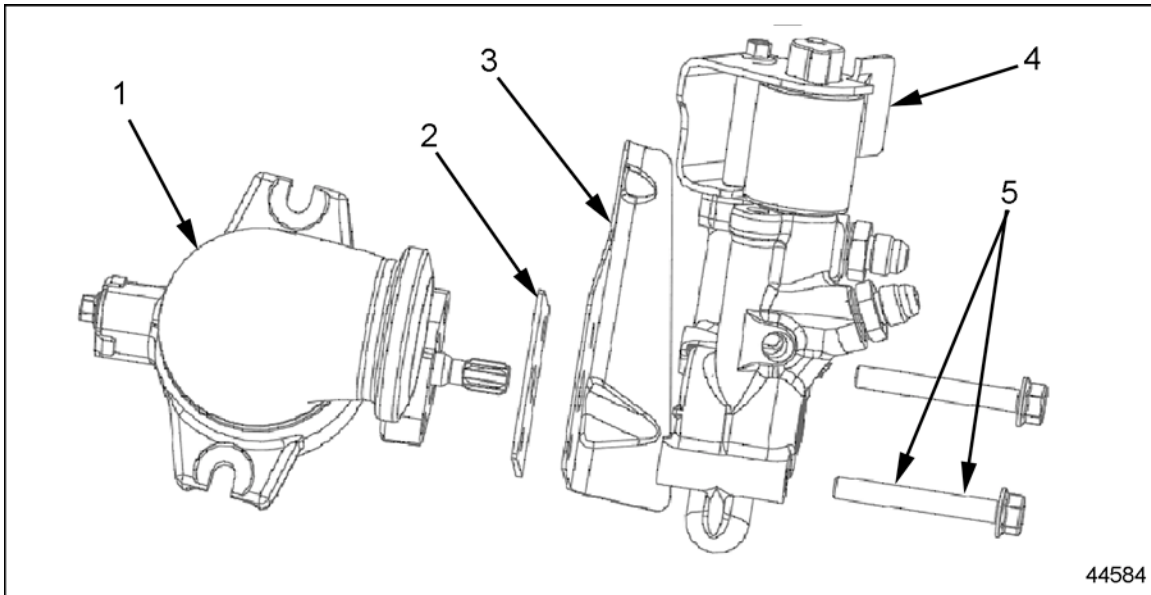

1. EGR Valve Assembly, P/N: 23534859
2. Shield, P/N: 23529735
3. Shield, P/N: 23532673
4. Hydraulic Actuator Assembly, P/N: 23533139
5. M8 Bolts, P/N: 11509515

Figure 3 Hydraulic Actuator EGR Valve Assembly

EGR Valve-to-EGR Cooler Installation

Install the EGR valve to the EGR cooler as follows:

1. Remove the “U” bolt assembly from the EGR cooler. See Figure 4. Discard only the “U” and two turnbuckle nuts.

NOTE:

It is planned that the “T” bolt assemblies, clevis pins, and cotter pins will be reused with this kit. If they cannot be reused, replacement parts can be ordered in Service Kit P/N: 23532831. Discard the unused parts.

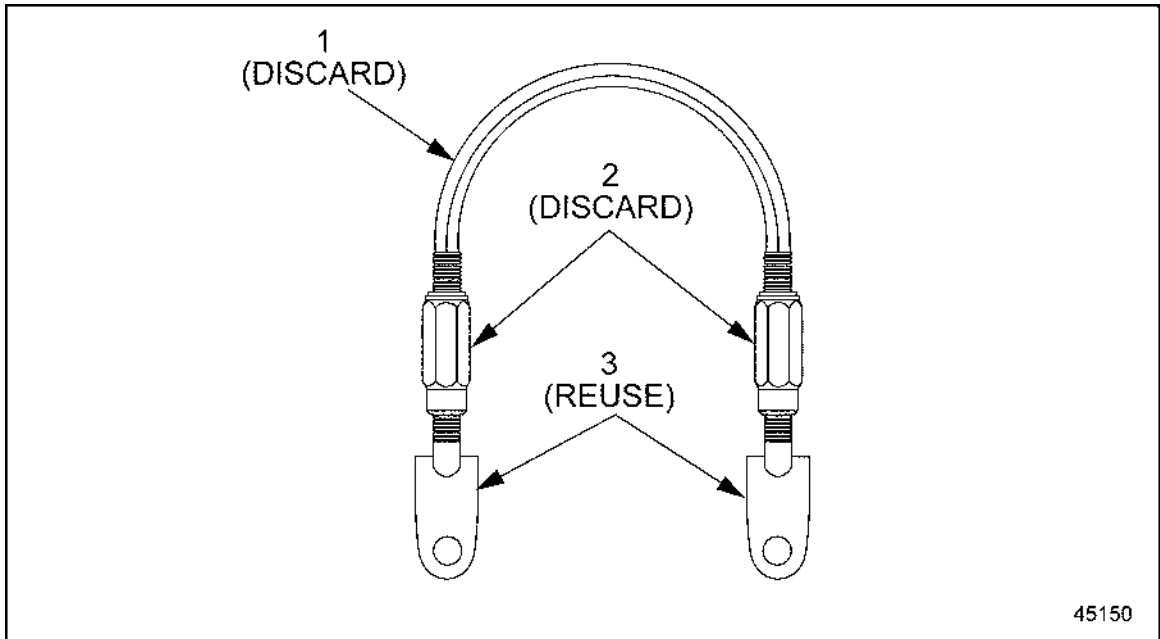

1. "U" Bolt
2. Turnbuckle nuts
3. "T" Bolt Assemblies

Figure 4 "U" Bolt Assembly

2. Remove spherical insert from EGR cooler with Kent-Moore® tool J-47195. See Figure 5. Take care not to damage the EGR cooler when removing the insert. Discard the insert.

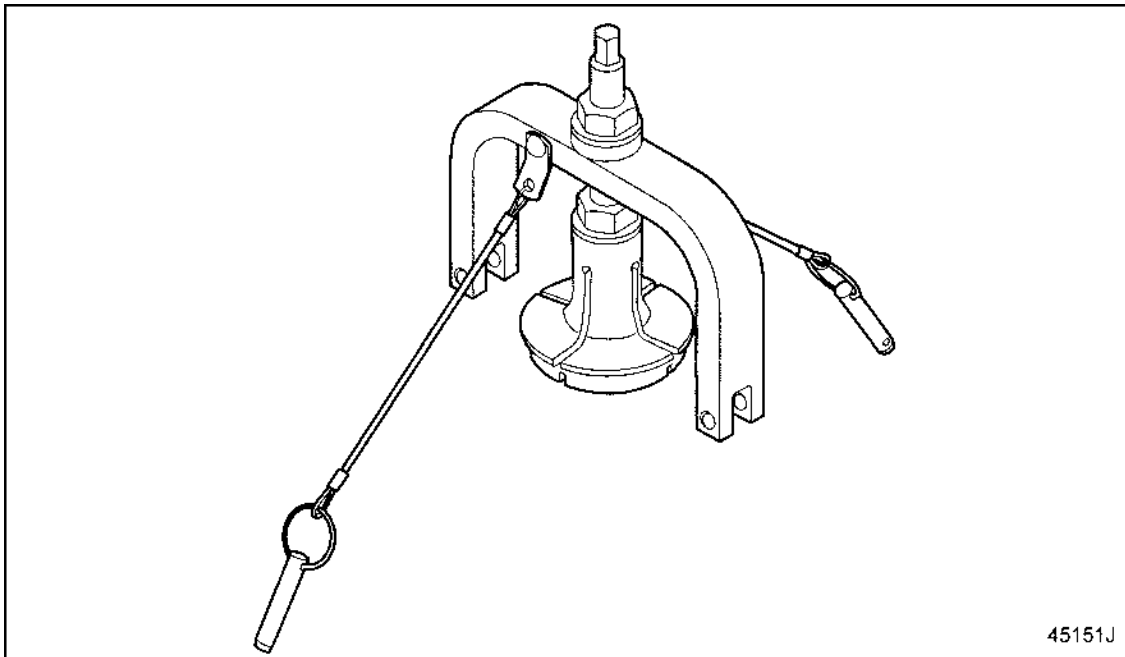

Figure 5 EGR Cooler Insert Removal Tool J-47195

3. Clean the sealing surface on the top, bottom, and internal diameter of the insert location. See Figure 6.

4. Reinstall the "T" bolts assemblies and two M8 x 10 nuts on EGR cooler.
5. Center the EGR valve over clevis and cooler ears with equal clearance on each side. See Figure 7.
6. Using even force, tighten the "T" bolts and press the EGR valve assembly completely into the EGR cooler as shown in Figure 7. Ensure there is NO gap between the valve and cooler. Torque nuts to 22-26 N·m (16-19 lb·ft).

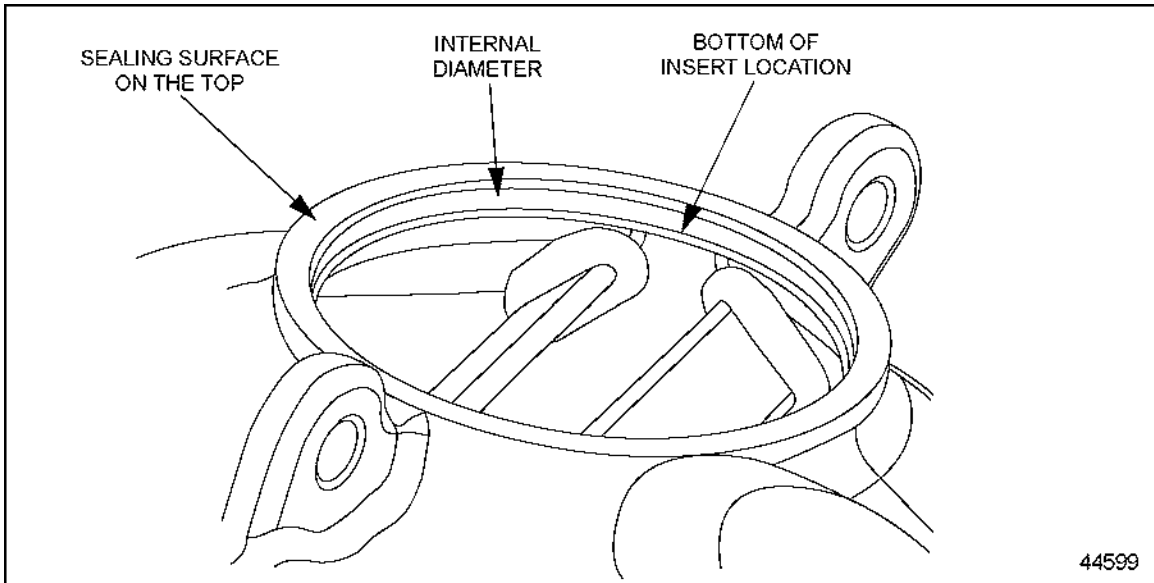

Figure 6 EGR Cooler Spherical Insert

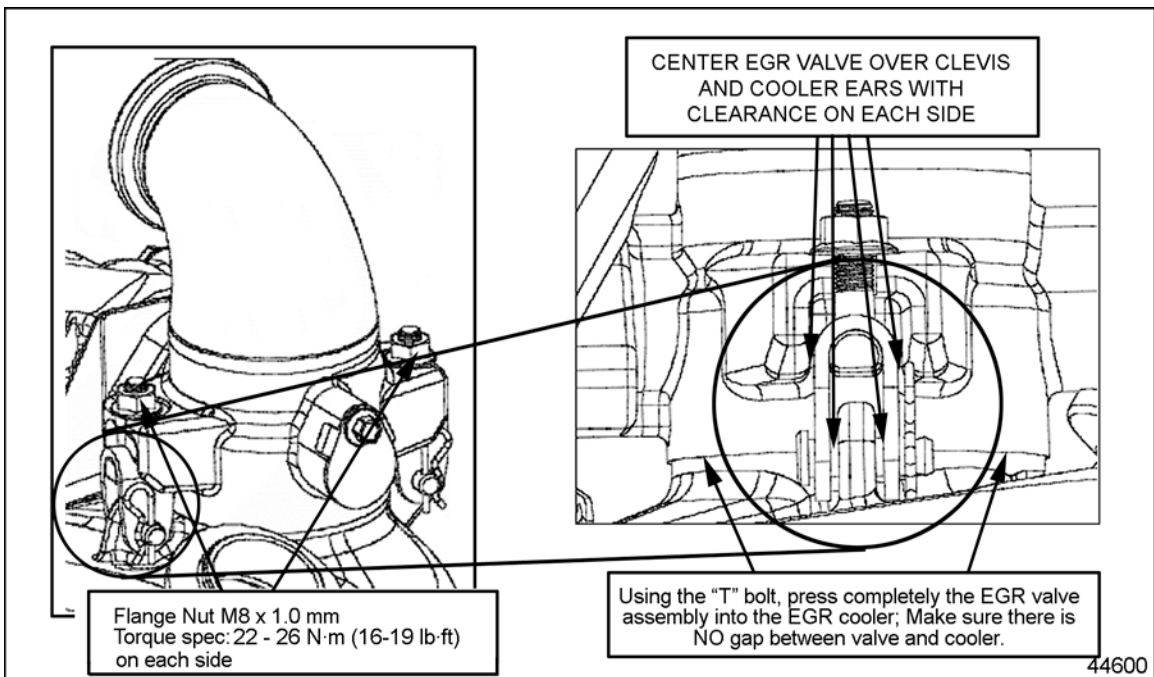
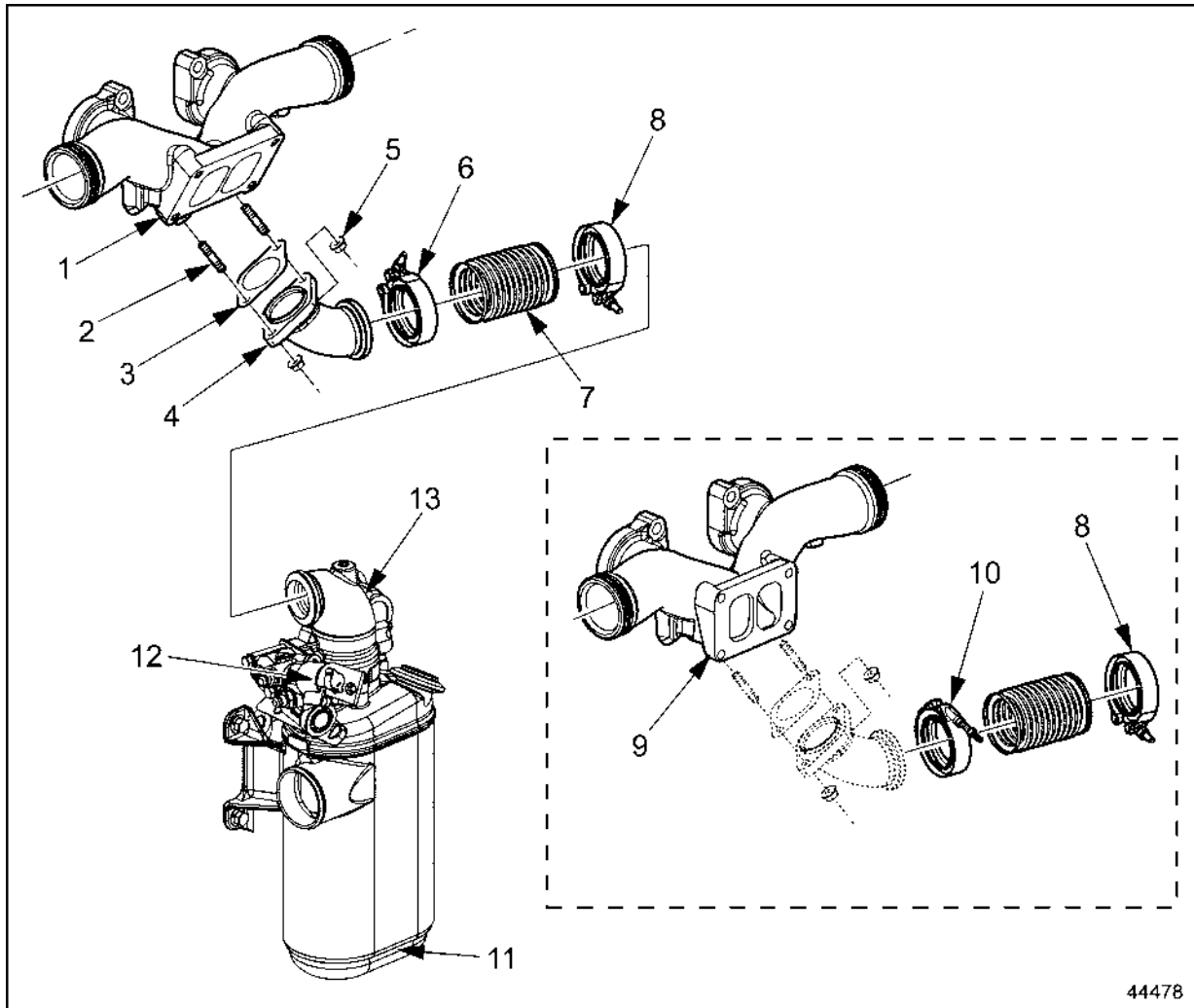

Figure 7 Hydraulic Actuator EGR Valve Assembly

EGR Bellows Installation

Install the bellows as follows:

1. Loosely install the two V-band clamps onto the upper hot pipe and EGR valve and position them as shown in Figure 8.
2. Compress and then slide the bellows in between the upper hot pipe and EGR valve. Turn the bellows by hand to ensure the end flanges are not damaged after installation.
3. Move the V-band clamps over the flanges and tighten to 12 N·m (106 lb·in.) Ensure that clamps are in the proper orientation as shown in Figure 8.



1. Exhaust Manifold Mid-Setback Center Section
2. Stud, M8 x 1.25
3. Gasket
4. Upper Hot Pipe
5. Nut, M8 x 1.25
6. Upper Hot Pipe-to-Bellows Clamp Orientation for a Mid-Setback Center Section
7. Bellows
8. EGR Valve-to-Bellows Clamp Orientation for all Engines
9. Exhaust Manifold High-Mount Center Section
10. Upper Hot Pipe-to-Bellows Clamp Orientation for a High-Mount Center Section
11. EGR Cooler with EGR Hydraulic Valve
12. Hydraulic Actuator Valve
13. EGR Valve

Figure 8 Exhaust Manifold Bellows Clamps Orientation

Table 2 is a description of kit parts, part numbers, and quantities required per hydraulic kit.

P/N:	Description	KIT 23534871 HYDRAULIC VALVE MID-SETBACK (Quantity)	KIT 23534872 HYDRAULIC VALVE HIGH-MOUNT (Quantity)
8929529	GASKET, TURBO MOUNTING	1	1
23533949	MAN. ASSY. EXHAUST CENTER SECTION (MID-SETBACK)	1	-
23533950	MAN. ASSY. EXHAUST CENTER SECTION (HIGH-MOUNT)	-	1
23533821	MAN. EXHAUST END SECTION FRT	1	1
23533822	MAN. EXHAUST END SECTION RR	1	1
23533707	STUD M8 X 1.25 NIMONIC	2	2
23533913	STUD, TURBO MOUNTING	4	4
23533210	UPPER HOT PIPE GASKET	1	1
23533221	UPPER HOT PIPE	1	1
23534432	NUT, M8 x 1.25 - TO CONNECT UPPER HOT PIPE TO CENTER SECTION EXHAUST MAN.	2	2
23534003	V-CLAMP	2	2
23533220	BELLOWS	1	1
23534859	EGR VALVE ASSY.	1	1
23529735	EGR VALVE ACTUATOR SHIELD	1	1
23533983	EXHAUST MANIFOLD GASKET	3	3
23531401	NUT, TURBO	4	4
8929169	WASHER, TURBO	4	4
23535039	NUT, M8 x 1.0 - TO CONNECT EGR VALVE TO EGR COOLER	2	2

Table 2 Description of Parts Hot Pipe Hydraulic Valve Service Kits

DETROIT DIESEL



13400 Outer Drive, West, Detroit, Michigan 48239-4001
Telephone: 313-592-5000
www.detroitdiesel.com

Copyright© 2004 Detroit Diesel Corporation. Detroit Diesel®, DDC®, and the spinning arrows design are registered trademarks of Detroit Diesel Corporation. All other trademarks are the property of their respective owners.

18SP596 0411 As technical advances continue, specifications will change. All rights reserved. Printed in U.S.A.