



Installation Instructions

18SP584* – Series 60[®] EGR Three-Piece Cold Pipe Assembly Kits

*Revision: 12/23/04

Introduction

There are seven new kits for different orientations of the three-piece cold pipe assemblies. Table 1 shows the correct kit part number for its corresponding engine type.

Kit Part No.	Description
23534150	Horizontal 12L Three-Piece Cold Pipe
23534151	Horizontal 14L Three-Piece Cold Pipe
23534152	Vertical 12L Three-Piece Cold Pipe
23534153	Vertical 14L Three-Piece Cold Pipe
23534154	Vertical Dual Alt 12L Three-Piece Cold Pipe
23534155	Vertical Dual Alt 14L Three-Piece Cold Pipe
23534156	Vertical EVO 12L Three-Piece Cold Pipe

Table 1 Available Three-Piece Delivery (Cold) Pipe Assembly Kits

It is extremely important to order the correct cold pipe kit and avoid the mistake of installing a 12L kit on a 14L engine, and vice versa. This incorrect repair can cause black smoke, DDEC codes, and will adversely affect the emissions compliance of the engine.

The kits are different with regards to basic hardware configuration. Figure 1 shows the 12L and 14L venturi tubes, which, if installed incorrectly, will cause the above-mentioned operational problems. Figure 2 shows the location of the model number on the block as well as a brief description of the letters used in a model number that identify a 12L from a 14L engine.

NOTE:

DO NOT BEND THE VENTURI TUBES FOR ANY REASON. If during the repair process, the Delta Pressure Sensor lines need to be “bent” to be connected, an improper kit is probably being used.

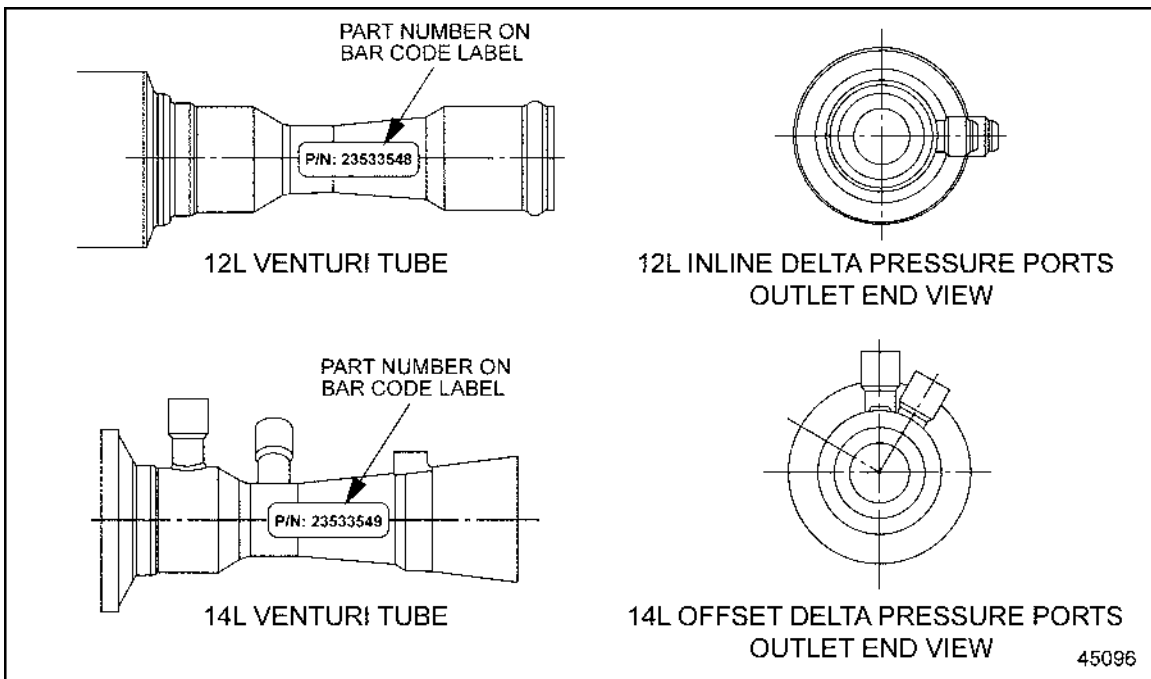

Figure 1 12L versus 14L Venturi Tubes

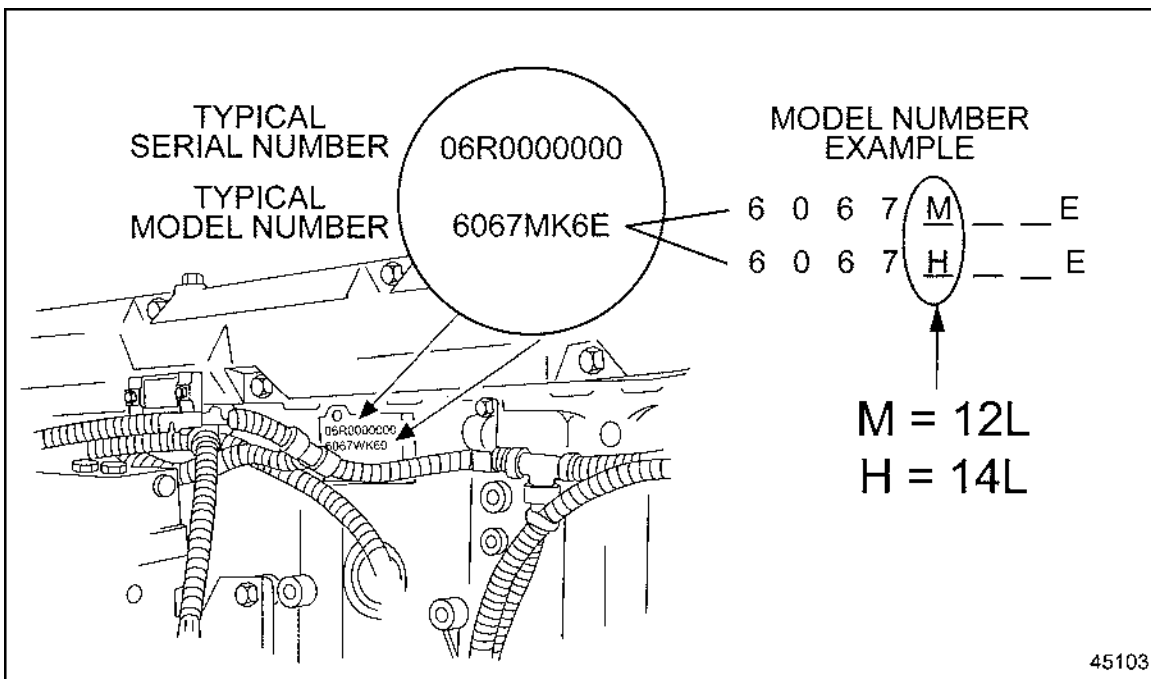

Figure 2 Model Number Location and Brief Description of Number

Installation

Perform the following steps to assemble and install a three-piece delivery pipe system. For clarity, instructions will pertain to a 14L horizontal manifold truck three-piece cold pipe kit. See Figure 3 for a typical diagram of a three-piece cold pipe assembly.

NOTE:

Install hose clamps on pipes before installing hoses.

1. Loosely install L-bracket to the top of the camshaft cover and S-bracket to the exhaust manifold. Invert P-clip on engine wire harness. Attach to L-bracket.

NOTE: This note is only for engines equipped with the air compressor inlet check valve mounted on TOP of the gear case:

A very small number of engines will require a different L-bracket than what was supplied in the kit. Engines equipped with the air compressor Inlet Check Valve (ICV) mounted on top of the gear case with bracket P/N: 23530896, will need to have new L-bracket P/N: 23532777 installed, instead of the L-bracket that comes in the kit.

2. Install hose on delivery pipe mixer-section and secure with spring clamp. Install hose on venturi section and secure with spring clamp.
3. Loosely install mixer section of delivery pipe to the intake manifold using band clamp.
4. Loosely install the venturi and center section on the EGR cooler using a clamp.
5. Align delivery pipe mid-section with the mixer section. Push the end of the delivery pipe mid-section onto the hose connection and secure with spring clamp.
6. Loosely install Delta-P tubes to venturi section and rotate venturi to align tubes with Delta-P sensor.
7. Loosely install P-clips (two at L-bracket and one at S-bracket).
8. Tighten the delivery pipe to intake mixer clamp to 12 N·m (106 lb·in.).

NOTE:

The seal between the intake manifold and the mixer is *not* required.

9. Tighten the clamp at the delivery pipe to cooler to 12 N·m (106 lb·in.).
10. Tighten the bolt and nut connecting the two P-clips to the gusseted L-bracket and the single P-clip to the S-bracket to 30-38 N·m (22-28 lb·ft).
11. Tighten the L-bracket bolts in the camshaft gear cover to 58-73 N·m (43-54 lb·ft).
12. Tighten the bolt into the heat shield to 30-38 N·m (22-28 lb·ft).
13. Tighten the Delta-P tube nuts to 24-28 N·m (18-21 lb·ft).

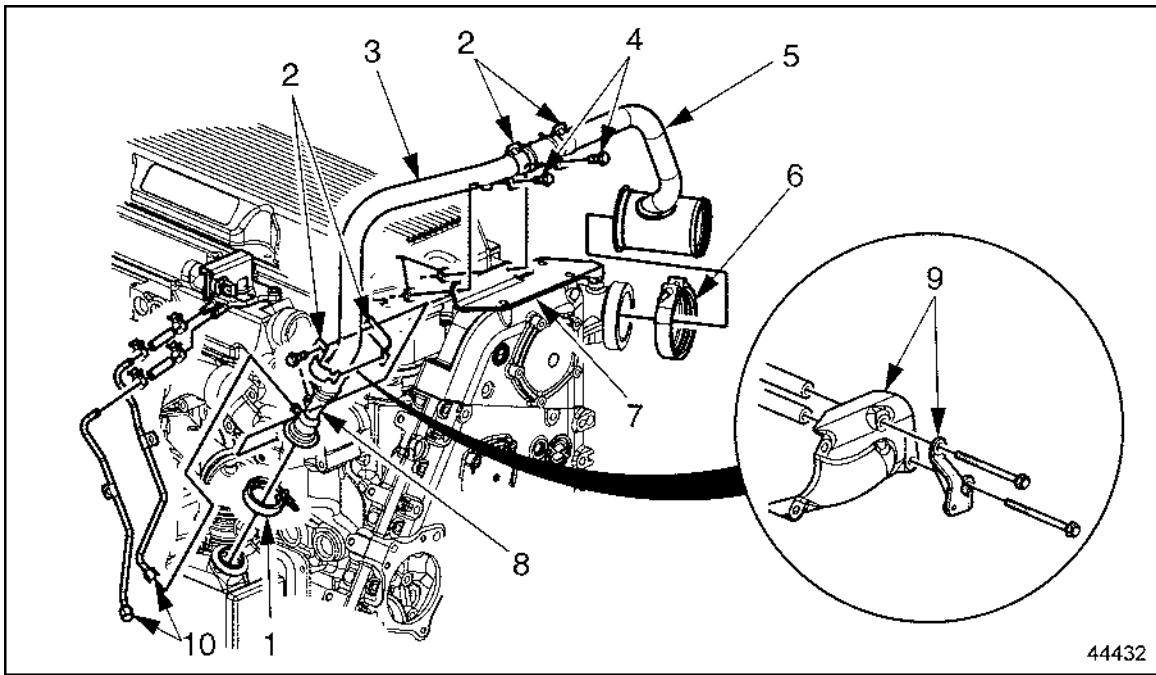

- | | |
|-----------------------------------|-------------------------------------|
| 1. Clamp | 6. Clamp |
| 2. P-Clip | 7. L-Bracket |
| 3. Mid-section of Delivery Pipe | 8. Venturi section of Delivery Pipe |
| 4. Bolt | 9. Heat Shield and S-Bracket |
| 5. Mixer section of Delivery Pipe | 10. Delta-P Tubes |

Figure 3 14L Horizontal Manifold Three-Piece Cold Pipe Assembly

Table 2 is a description of all kit parts, part numbers, and quantities required per kit.

UPC	Description	P/N:	23534150	23534151	23534152	23534153	23534154	23534155	23534156
6L4A	BOLT- M8x1.5x20	11509511	3 QTY.	3 QTY.	3 QTY.	3 QTY.	3 QTY.	3 QTY.	3 QTY.
6L4A	BOLT- M10x1.5x25	23511786	3	3	3	3	3	3	3
6L4A	P-CLIP	23530618	3	3	3	3	3	3	3
6L4A	CLAMP- SPRING WIRE	23531128	4	4	4	4	4	4	4
6L4A	CLAMP- SPRING WIRE	23516419	—	—	—	—	2	2	—
6L4A	COLD PIPE- MID SECTION	23533375	1	1	1	1	—	—	—
6L4A	COLD PIPE- MID SECTION	23533377	—	—	—	—	1	1	—
6L4A	COLD PIPE- MID SECTION	23533380	—	—	—	—	—	—	1
6L4A	COLD PIPE- MIXER	23533376	1	1	—	—	—	—	—
6L4A	COLD PIPE- MIXER	23533379	—	—	1	1	1	1	—
6L4A	COLD PIPE- MIXER	23533381	—	—	—	—	—	—	1
6L4A	HOSE- VENTURI CONNECTION	23533440	1	1	1	1	1	1	1
6L4A	HOSE-MIXER CONNECTION	23533441	1	1	1	1	1	1	1
6L4A	BRACKET	23533443	1	1	1	1	—	—	1
6L	BRACKET	23533444	1	1	1	1	1	1	1
6Y1	BRACKET	23533712	—	—	—	—	1	1	—
6L4A	VENTURI-12L	23533548	1	—	1	—	1	—	1
6L4A	VENTURI-14L	23533549	—	1	—	1	—	1	—
6K3A	TUBE-WATER BYPASS	23533446	—	—	—	—	1	1	—
6K3A	HOSE	23533447	—	—	—	—	2	2	—
6L	BOLT	23533687	2	2	2	2	2	2	2
6L	FRONT HEAT SHIELD	23533695	1	1	1	1	1	1	1
6L4A	CLAMP- INTAKE MANIFOLD	23533977	1	1	1	1	1	1	1
6K3A	CLAMP- SPRING WIRE	23533699	—	—	—	—	2	2	—
6L4A	CLAMP-EGR COOLER	23534003	1	1	1	1	1	1	1

Table 2 Description of Parts for All Three-Piece Delivery (Cold) Pipe Kits

DETROIT DIESEL



13400 Outer Drive, West, Detroit, Michigan 48239-4001
Telephone: 313-592-5000
www.detroitdiesel.com

Copyright© 2004 Detroit Diesel Corporation. Detroit Diesel®, DDC®, and the spinning arrows design are registered trademarks of Detroit Diesel Corporation. All other trademarks are the property of their respective owners.
18SP584 (Rev. 12/23/04) 0412 As technical advances continue, specifications will change. All rights reserved. Printed in U.S.A.