

# DETROIT DIESEL



## Installation Instructions

### 18SP581 – Series 60<sup>®</sup> EGR Cooler Service Replacement Kit P/N: 23533985

#### Introduction

The 2004 released tube and shell EGR cooler is available as a service replacement for the 2002 released bar fin and plate EGR cooler. All former EGR cooler part numbers will be superseded to the current EGR cooler kit part number 23533985. See Table 1 for the kit contents:

Part No.	Qty.	Description
23533179	1	EGR Cooler
18SP581	1	Installation Instructions

**Table 1 S60 EGR Cooler Service Replacement Kit P/N: 23533985**

#### Installation

Series 60 EGR engines built prior to 06R0755298 with DDEC IV and the former style EGR cooler will be **required** to have the ECM reprogrammed because of the higher efficiency of the current (P/N: 23533179) cooler. When a tube and shell style cooler is used to replace the bar fin and plate type, the ECM **must** be reprogrammed. There is no mainframe change required as all Series 60 DDEC IV calibrations have been updated. Download the unit file and reprogram the ECM. There are no concerns if an updated calibration is programmed into an engine that still has the bar fin and plate cooler. A technician can confirm the ECM programming is configured for the tube and shell cooler by verifying that the ECM software level has changed to 37.00 or higher.

See Figure 1 for identification of the former and current cooler. Inspect coolant hoses and change if necessary.

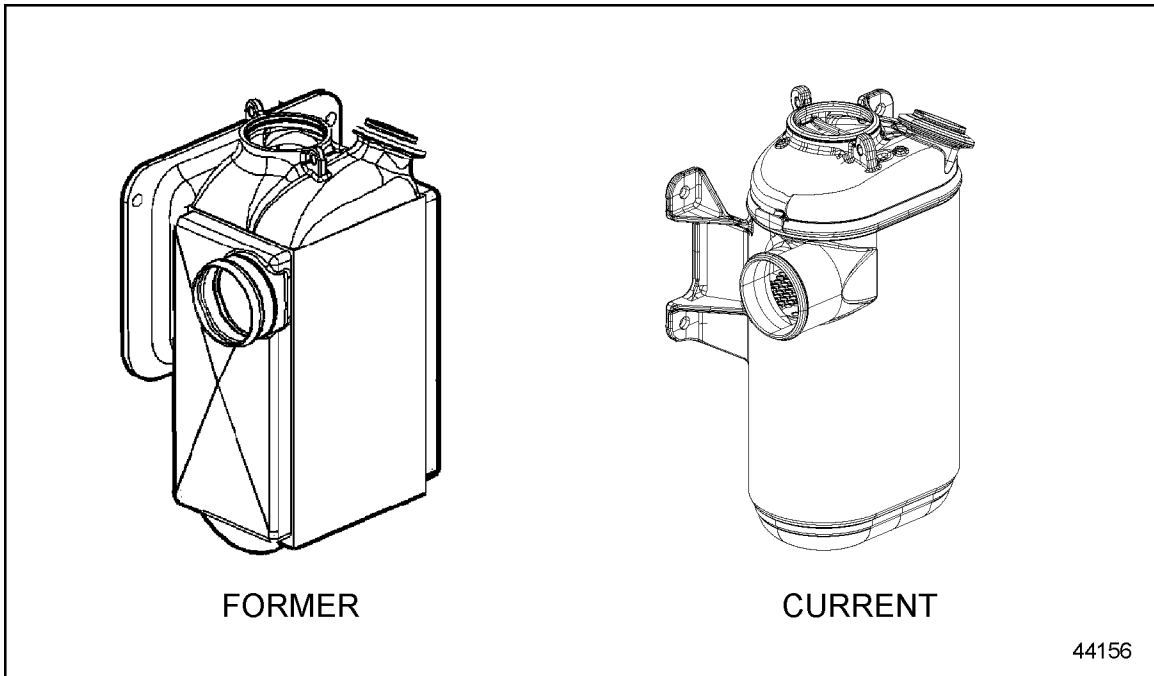

**Figure 1 Identification of Former and Current EGR Cooler**

**NOTE:**

Series 60 engines built after 06R0755298 with DDEC V **do not require** any programming changes because the EGR cooler is a direct replacement.

**DETROIT DIESEL**



13400 Outer Drive, West, Detroit, Michigan 48239-4001  
Telephone: 313-592-5000  
[www.detroitdiesel.com](http://www.detroitdiesel.com)

Copyright© 2004 Detroit Diesel Corporation. Detroit Diesel®, DDC®, and the spinning arrows design are registered trademarks of Detroit Diesel Corporation. All other trademarks are the property of their respective owners.  
**18SP581 0401 As technical advances continue, specifications will change. All rights reserved. Printed in U.S.A.**