



## Installation Instructions

### 18SP577 - New Exhaust Manifold Slip Joint Seal Kit P/N 23533543 for Series 60<sup>®</sup> Engines

#### Introduction

There is a new service kit available for sealing the exhaust manifold slip joints on Series 60 engines and should be used as an alternative to manifold replacement when the complaint is exhaust leakage from this area. The kit was primarily developed because of the higher exhaust manifold pressures associated with the EGR engines; however, the kit will also work for non-EGR Series 60 engines.

#### Installation

This kit, P/N 23533543, consists of the following parts (See Table 1) and see Figure 1:

Part Number	Qty.	Description
23533273	1	Seal
23533274	2	Covers
23533275	1	Clamp
18SP577	1	Instructions

Table 1 P/N: 23533543 Kit Description of Parts

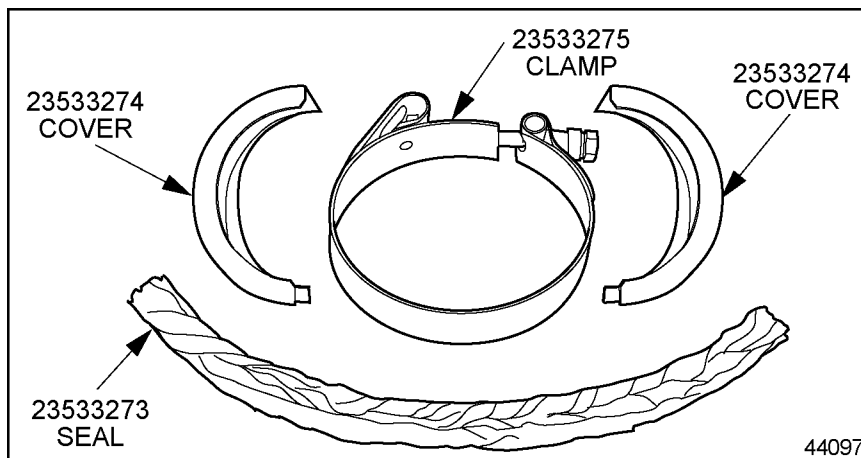

Figure 1 P/N: 23533543 Exhaust Manifold Slip Joint Seal Kit

Perform the following steps to install the slip joint seal kit :



#### CAUTION:

To avoid injury from hot surfaces, allow engine to cool before removing any component. Wear protective gloves.

1. Remove the rear manifold heat shield.
2. The large lip of the covers is always toward the turbocharger, and the area where the lip is removed must be towards the cylinder head. See Figure 2. The split lines of the covers should be located horizontally and the split of the seal should be located vertically.

**NOTE:** Do not align the split lines of the cover and seal.

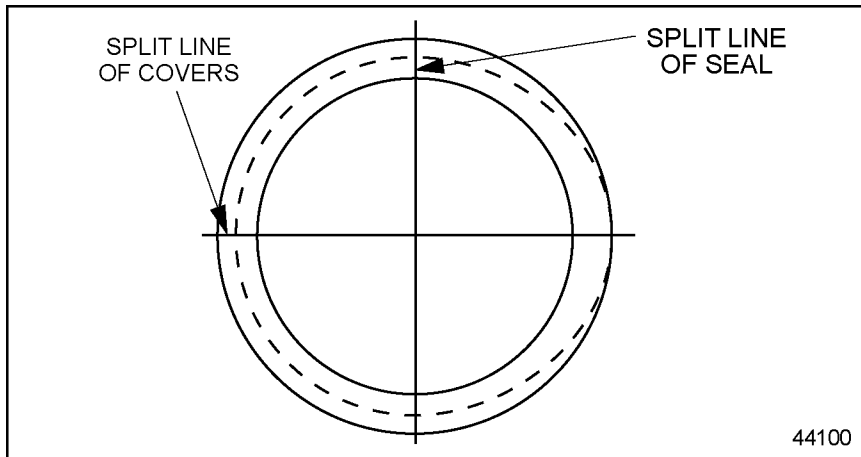

**Figure 2 Location of Installed Covers and Seal**

Parts are a tight fit under the thermostat housing and may require a screwdriver on top of the cover to compress the seal and roll the top cover into place.

3. The clamp has a removable “T” bolt for ease of installing and care should be taken to locate the clamps so that the nuts can be reached and clear the heat shield in the rear. Torque the clamps until the cover split lines touch.
4. Reinstall the rear heat shield, and slightly pry the heat shield up and away from the rear seal cover.

**DETROIT DIESEL**



13400 Outer Drive, West, Detroit, Michigan 48239-4001  
Telephone: 313-592-5000  
www.detroitdiesel.com

Copyright© 2003 Detroit Diesel Corporation. Detroit Diesel®, DDC®, and the spinning arrows design are registered trademarks of Detroit Diesel Corporation. All other trademarks are the property of their respective owners.  
**18SP577 0312 As technical advances continue, specifications will change. All rights reserved. Printed in U.S.A.**