

DETROIT DIESEL



Installation Instructions

18SP568 – Install Front PTO Driveline on Series 60[®] Engine

Introduction

This kit permits the installation of a front PTO driveline on a Series 60 engine. Kit components are listed in Table 1.

Part No.	Qty.		Description
	A	B	
23532867	1		Kit, PTO Driveline (includes items in column A)
23532868		1	Kit, PTO Driveline (includes items in column B)
23532731	1		- PTO Shaft Assembly
23532732		1	- PTO Shaft Assembly
23532685	1	1	- Clutch Adaptor
23531647	1	1	- Coupling Assembly (w/bolts)
18SP568	1	1	- Installation Instructions

Table 1 Components of Kits 23532867 and 23532868

Assemble Kit

Assemble the kit as follows:

1. If not previously removed, remove the PTO assembly from the engine.
2. Remove the nut and lock washer from the center of the PTO assembly.

NOTICE:

A protective sleeve may be installed on the end of the shaft to prevent damage to the bearing surface. Do not remove this sleeve until ready to install the PTO onto the engine.

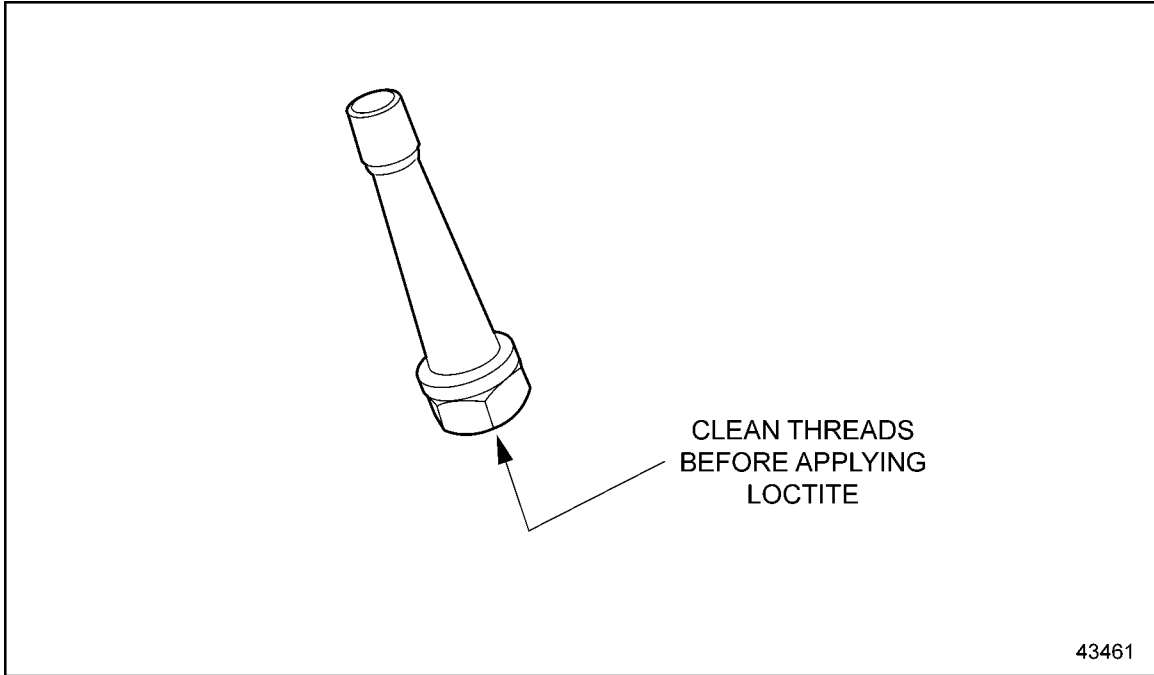

Figure 1 Clean Shaft Threads Before Installing into PTO

3. Using brake cleaner or other commercial de-greaser, thoroughly clean the female threads of the new shaft assembly and the male threads on the PTO shaft to ensure they are free of oil and grease. *Do not use mineral spirits, since this will leave a film. Do not allow the de-greaser to run onto the shaft bearing, since this may affect the bearing lubricant.* See Figure 1.
4. Apply medium strength Loctite® (blue color) to the shaft threads and install onto the PTO assembly. See Figure 1.

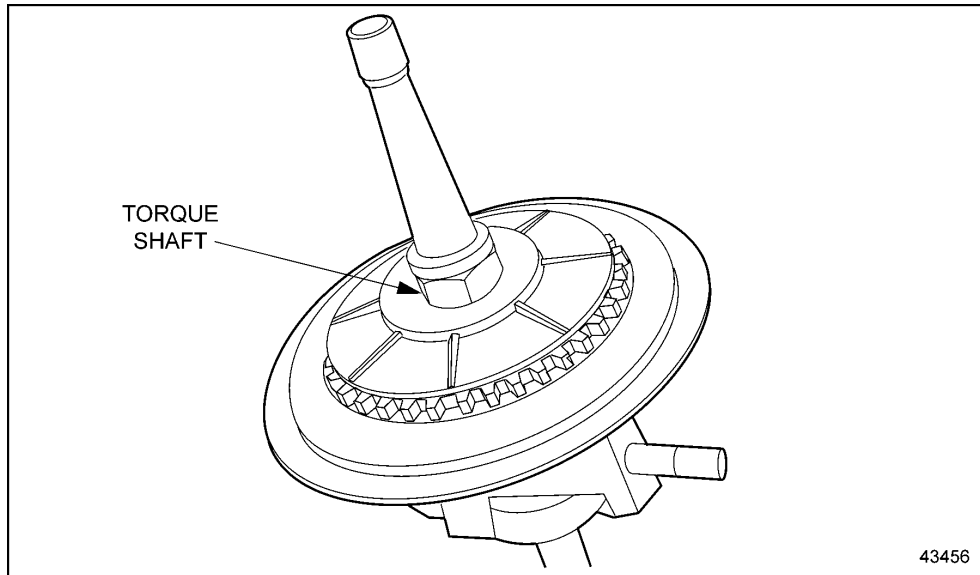

Figure 2 Install Shaft and Torque –Turn to Specifications

5. Torque-turn shaft nut as follows:

Shaft Part Number	Torque-Turn
23532731	30 lb-ft (41 N·m) + 60° - 90°
23532732	39 lb-ft (53 N·m) + 120° - 150°

6. Position the PTO ring gear (not part of kit) and coupling on the clutch adaptor plate. Install the ring gear bolts and torque to 156 – 204 lb-in.
7. Install coupling bolts and torque to 258 lb-ft (350 N·m). See Figure 3.

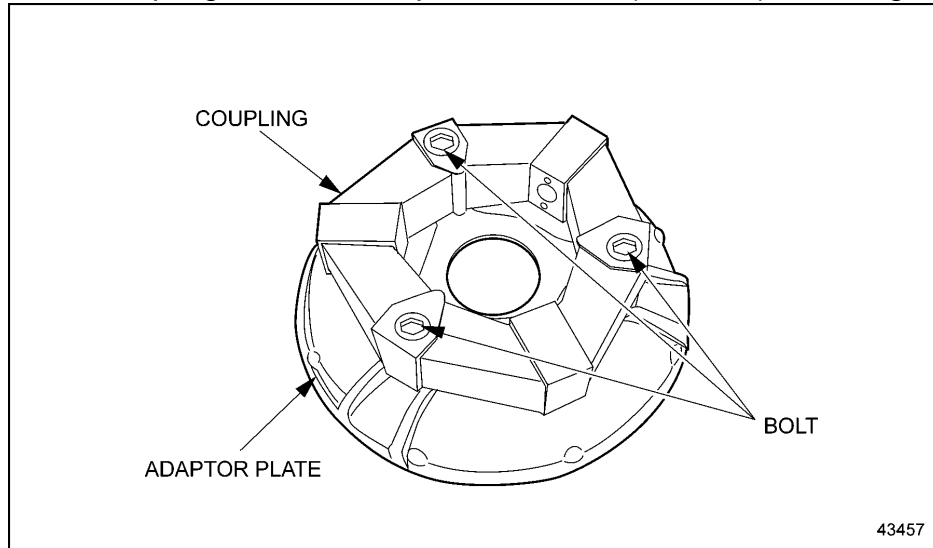

Figure 3 Install Ring Gear and Coupling onto Adaptor Plate

8. Apply light oil to the shaft bearing and inner diameter of the adaptor plate for ease of installation.
9. Using the shaft bearing as a pilot, install the clutch adaptor plate and coupling onto the PTO assembly. See Figure 4.

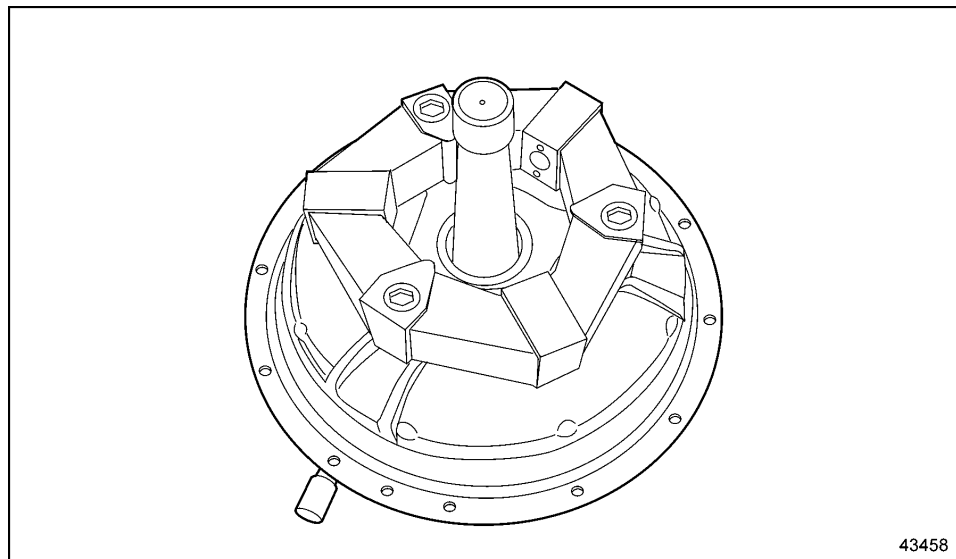

Figure 4 Install Adaptor Plate/Coupling onto PTO

10. If installed, remove the protective sleeve from the end of the PTO bearing race, clean thoroughly, and grease.

NOTE:

The mate to the bearing race was installed and greased in the factory.

NOTE:

Before the coupling-to-hub retaining bolts can be installed, the top bolthole in the coupling must be perfectly aligned with the top bolthole in the hub and accessible through the tool window in the PTO housing.

11. Using the pulley bearing as a pilot for lining up the driveline shaft, carefully install the PTO assembly onto the engine, ensuring that the top coupling and hub boltholes line up and are accessible through the tool window. See Figure 5.

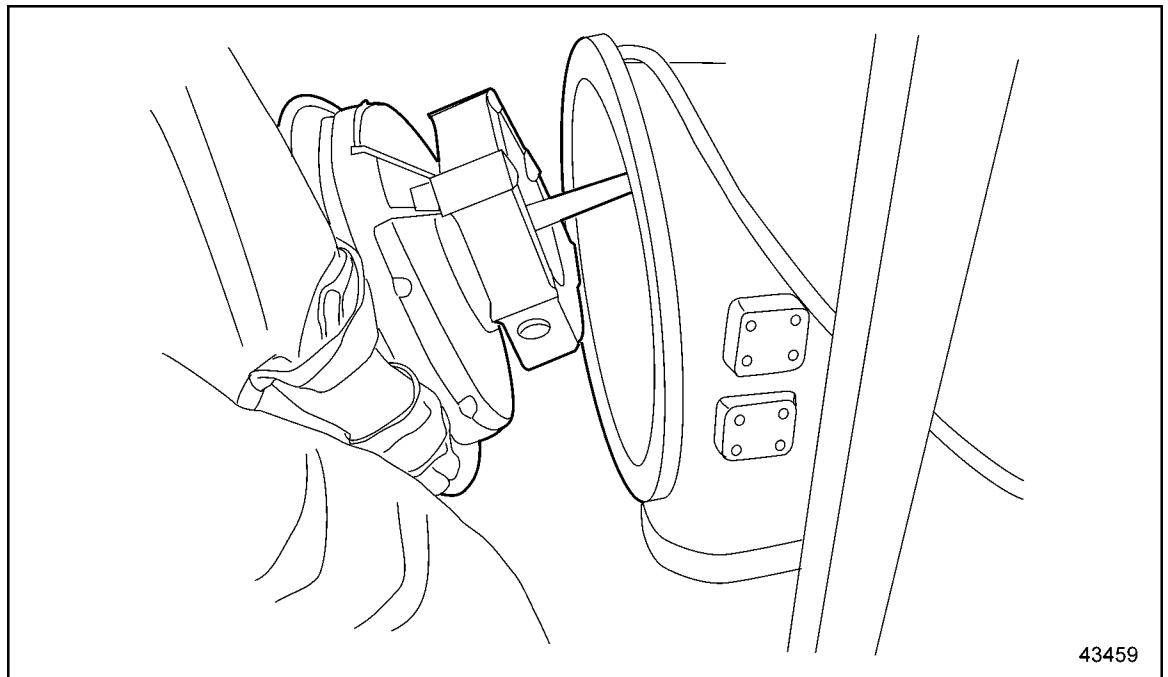

Figure 5 Install PTO Assembly onto Engine

12. Install the PTO housing-to-engine bolts and torque to 30 – 35 lb-ft (41–47 N·m).

NOTE:

Due to coupling deflection, install and tighten each coupling-to-hub bolt only 1-½ turns before barring the engine and installing the next bolt. This will help ensure proper coupling/hub alignment.

13. Install the first coupling bolt through the coupling and into the hub, but tighten only 1 ½ turns. Bar the engine and install the remaining two bolts, tightening each only 1 ½ turns.
14. When all three coupling bolts have been installed, torque bolts to 258 lb-ft (350 N·m).
15. Verify that crankshaft end play is within 0.0039 – 0.0165 in. (0.099 – 0.419 mm).

DETROIT DIESEL



13400 Outer Drive, West, Detroit, Michigan 48239-4001
Telephone: 313-592-5000
www.detroitdiesel.com

18SP568 - Page 6 of 6

Copyright © 2003 Detroit Diesel Corporation. Detroit Diesel,® DDC® and Series 60® are registered trademarks of Detroit Diesel Corporation. Loctite® is a registered trademark of the Loctite Corporation.

18SP568 0304 As technical advances continue, specifications will change. All rights reserved. Printed in U.S.A.