

DETROIT DIESEL

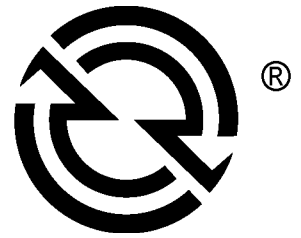

ATS Technician's Guide

NUMBER: 07 ATS-3 **S.M. REF.:** Listed in Table 1 **ENGINE:** ATS **DATE:** December 2007

SUBJECT: ADDITIONAL PROCEDURES WERE ADDED TO AFTERTREATMENT SYSTEM

PUBLICATION: 7SE63

The *Aftertreatment System Technician's Guide* (7SE63) was revised to include three new procedures.

MANUAL REFERENCE

Section	Change
6.2.2, DERATE-ENGINE PROTECTION FAULT CODE	Fault codes 3242/8, 3250/8, and 3609/8 were added to the Table 4-1 and Table 4-2.
9.4, SPN 3242/FMI 8	Troubleshooting for DOC Inlet Temperature signal spike (SPN 3242/FMI 8) was added.
11.5, SPN 3250/FMI 8	Troubleshooting for DOC Outlet Temperature signal spike (SPN 3250/FMI 8) was added.
18.4, SPN 3609/FMI 8	Troubleshooting for DPF Outlet Temperature signal spike (SPN 3609/FMI 8) was added.

Table 1 Manual Revisions

DERATE-ENGINE PROTECTION FAULT CODE

SPN Code Number	FMI	Code Description
51	2	Intake Throttle Position Deviation Error
51	3	Intake Air Throttle Circuit Failed High
51	4	Intake Air Throttle Circuit Failed Low
94	3	Fuel Compensation Pressure Sensor Circuit Failed High
94	4	Fuel Compensation Pressure Sensor Circuit Failed Low
3242	2	DOC Inlet Temperature Sensor Plausibility Error
3242	3	DOC Inlet Temperature Circuit Failed High
3242	4	DOC Inlet Temperature Circuit Failed Low
3242	8	DOC Inlet Temperature Signal Spike
3242	10	DOC Inlet Temperature Sensor Stuck
3246	0	DPF Outlet Temperature High
3246	2	DPF Outlet Sensor General Temperature Plausibility
3246	3	DPF Outlet Temperature Circuit Failed High
3246	4	DPF Outlet Temperature Circuit Failed Low
3246	10	DPF Outlet Temperature Sensor Stuck
3246	14	Abnormal DPF Temperature Rise

Table 2 Aftertreatment System Codes (1 of 3)

SPN Code Number	FMI	Code Description
3250	0	DOC Outlet Temperature Too High
3250	2	DOC Outlet Temperature Sensor Plausibility Error
3250	3	DOC Outlet Temperature Circuit Failed High
3250	4	DOC Outlet Temperature Circuit Failed Low
3250	8	DOC Outlet Temperature Signal Spike
3250	10	DOC Outlet Temperature Sensor Stuck
3250	14	Abnormal DOC Temperature Rise (2)
3250	31	Abnormal DOC Temperature Rise (1)
3251	0	DPF Outlet Pressure Out of Range Very High
3251	1	DPF Outlet Pressure Out of Range Low
3251	16	DPF Outlet Pressure Out of Range High
3464	14	Intake Air Throttle Control Circuit Electrical Fault
3471	1	Electronic Dosing Valve Failed Self Test
3471	3	Electronic Dosing Valve Circuit Failed High
3471	4	Electronic Dosing Valve Circuit Failed Low
3471	5	Electronic Dosing Valve Circuit Failed Open
3480	1	Doser Fuel Supply Pressure Abnormal
3480	2	Doser Fuel Line Pressure Abnormal
3480	14	Doser Fuel Line Pressure Sensor Failed Self Test
3480	31	Fuel Cutoff Valve Failed Self Test
3482	3	Fuel Cutoff Valve Circuit Failed High
3482	4	Fuel Cutoff Valve Circuit Failed Low
3482	5	Fuel Cutoff Valve Circuit Open
3482	7	Fuel Cutoff Valve Failed Self Test
3556	0	Regen Temperature Out of Range High
3556	1	Regen Temperature Out of Range Low
3609	2	DPF Inlet Pressure Sensor Drifted High in Range Fault (High Box)
3609	3	DPF Inlet Pressure Circuit Failed High
3609	4	DPF Inlet Pressure Circuit Failed Low
3609	8	DPF Outlet Temperature Signal Spike
3609	10	DPF Inlet Pressure Sensor Stuck
3609	20	DPF Inlet Pressure Sensor Drifted High in Range Fault (Low Box)
3609	21	DPF Inlet Pressure Sensor Drifted Low in Range Fault (Low Box)

Table 3 Aftertreatment System Codes (2 of 3)

SPN 3242/FMI 8

This diagnostic condition indicates the MCM has detected an impossible temperature shift on the DOC Inlet Temperature Sensor. The most likely cause is an intermittent wiring problem. See Figure 1 and Figure 2 for the ATD wiring schematics.

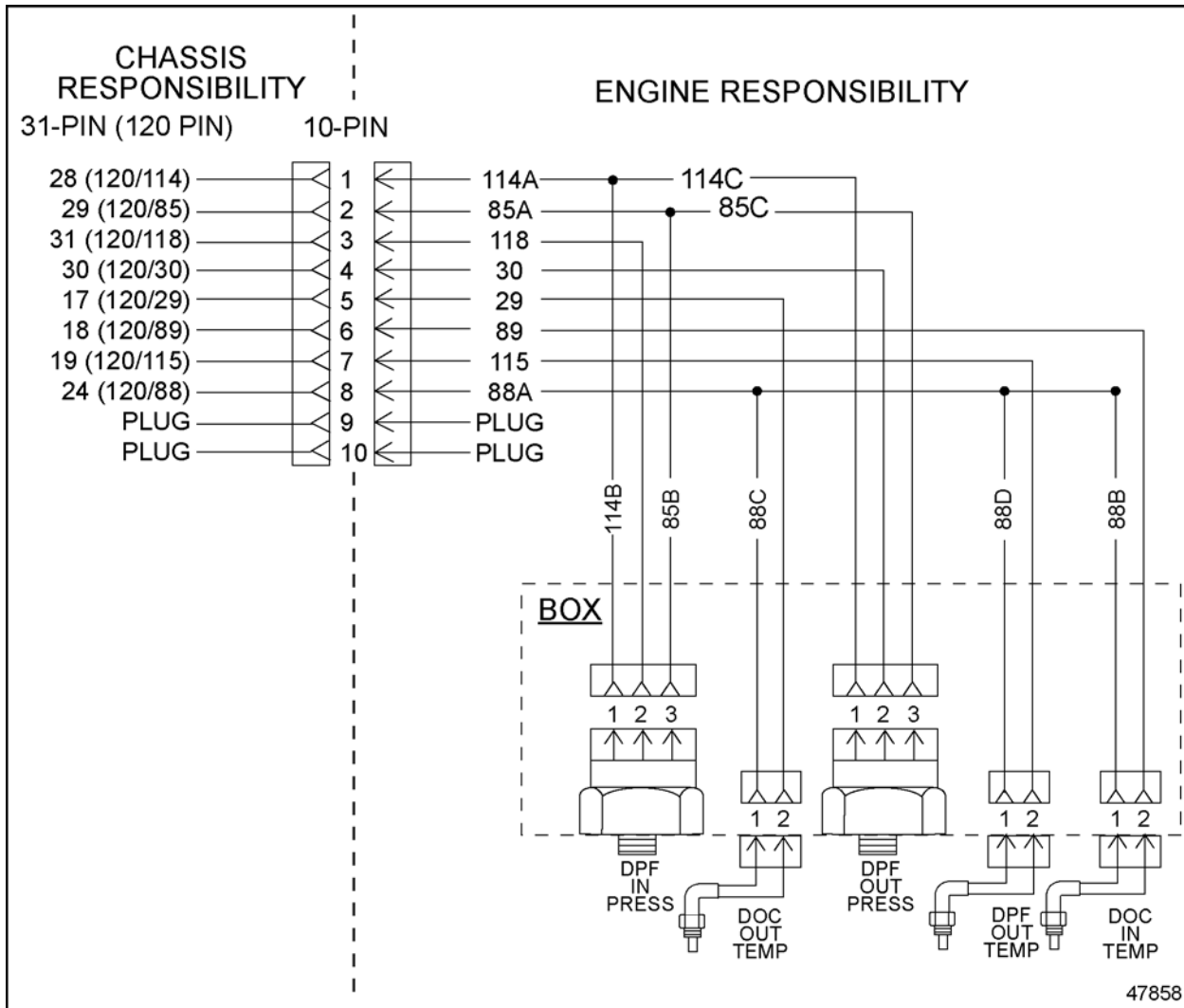

Figure 1 Vertical Aftertreatment Device Wiring Diagram

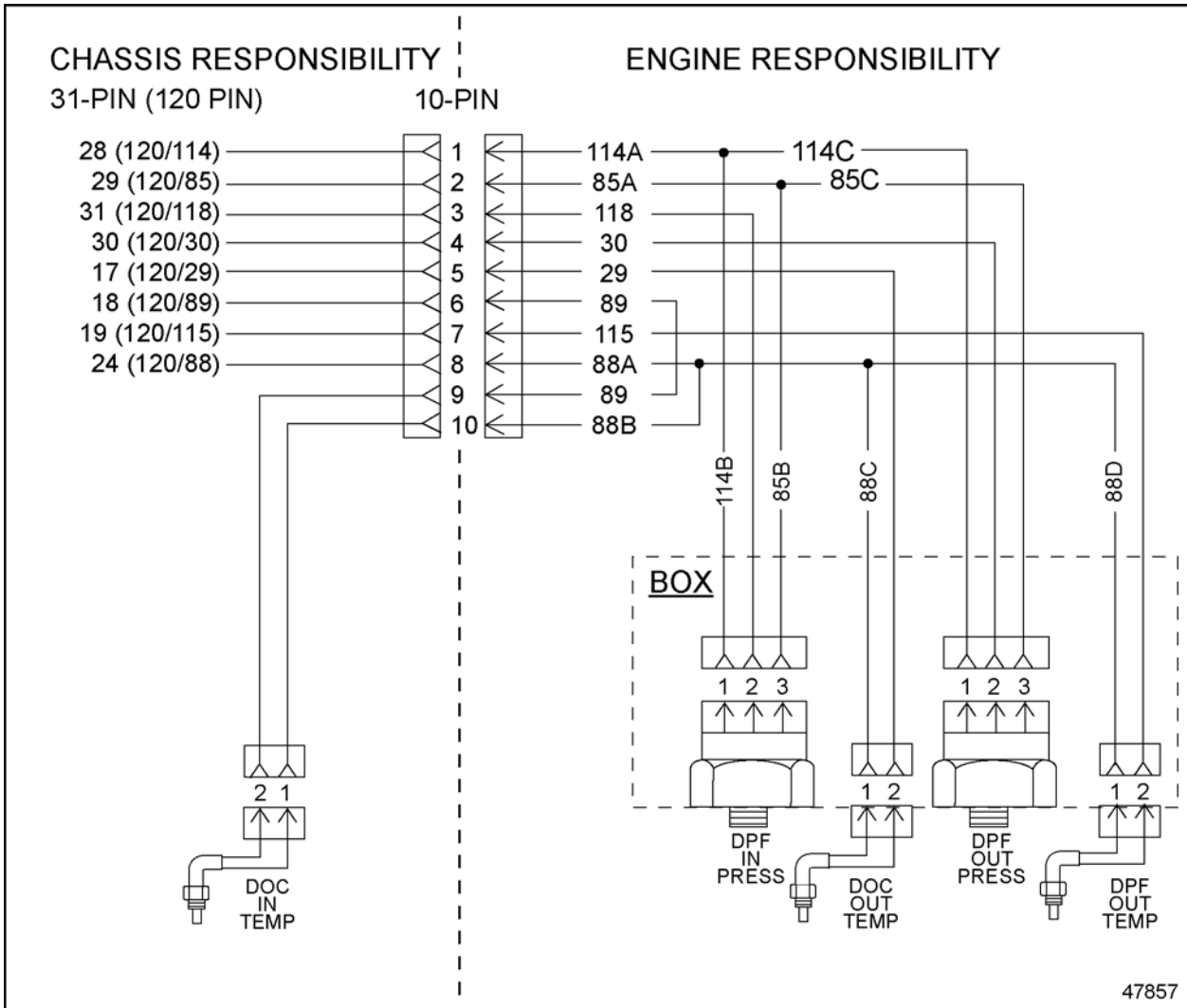

Figure 2 Horizontal Aftertreatment Device Wiring Diagram

CHECK FOR DIESEL OXIDATION CATALYST INLET TEMPERATURE SENSOR TEMPERATURE WIRING PROBLEM

Check as follows:

1. Connect DDDL 7.0 or later version.
2. Turn ignition ON (key ON, engine OFF).
3. Check for multiple codes.
 - [a] If fault 3242/3 or 3242/4 is active, troubleshoot this fault first. Verify repairs.
 - [b] If fault 3242/3 or 3242/4 and fault 3242/8 are inactive, go to step 4.



**CAUTION:
EXHAUST FUMES**

To avoid injury or injury to bystanders from fumes, engine or vehicle fuel system service operations should be performed in a well ventilated area.

4. Start engine.
5. Access the Voltage Service Routine.
6. Select “Start Acquiring”.
7. Wiggle test the harness while looking for abnormal voltage spikes on T_DOC_IN (pin 89).
 - [a] If a voltage spike is detected, isolate that section of harness and inspect for wiring chaffing, corrosion, improper connections, or physical damage. Repair damage as necessary. Verify repairs.
 - [b] If no voltage spikes are seen, physically check and clean all harness connectors between the DOC Inlet Temperature Sensor and the MCM. Repair damage as necessary. Verify repairs.

SPN 3250/FMI 8

This diagnostic condition indicates the MCM has detected an impossible temperature shift on the DOC Outlet Temperature Sensor. The most likely cause is an intermittent wiring problem. See Figure 3 and Figure 4 for the ATD wiring schematics.

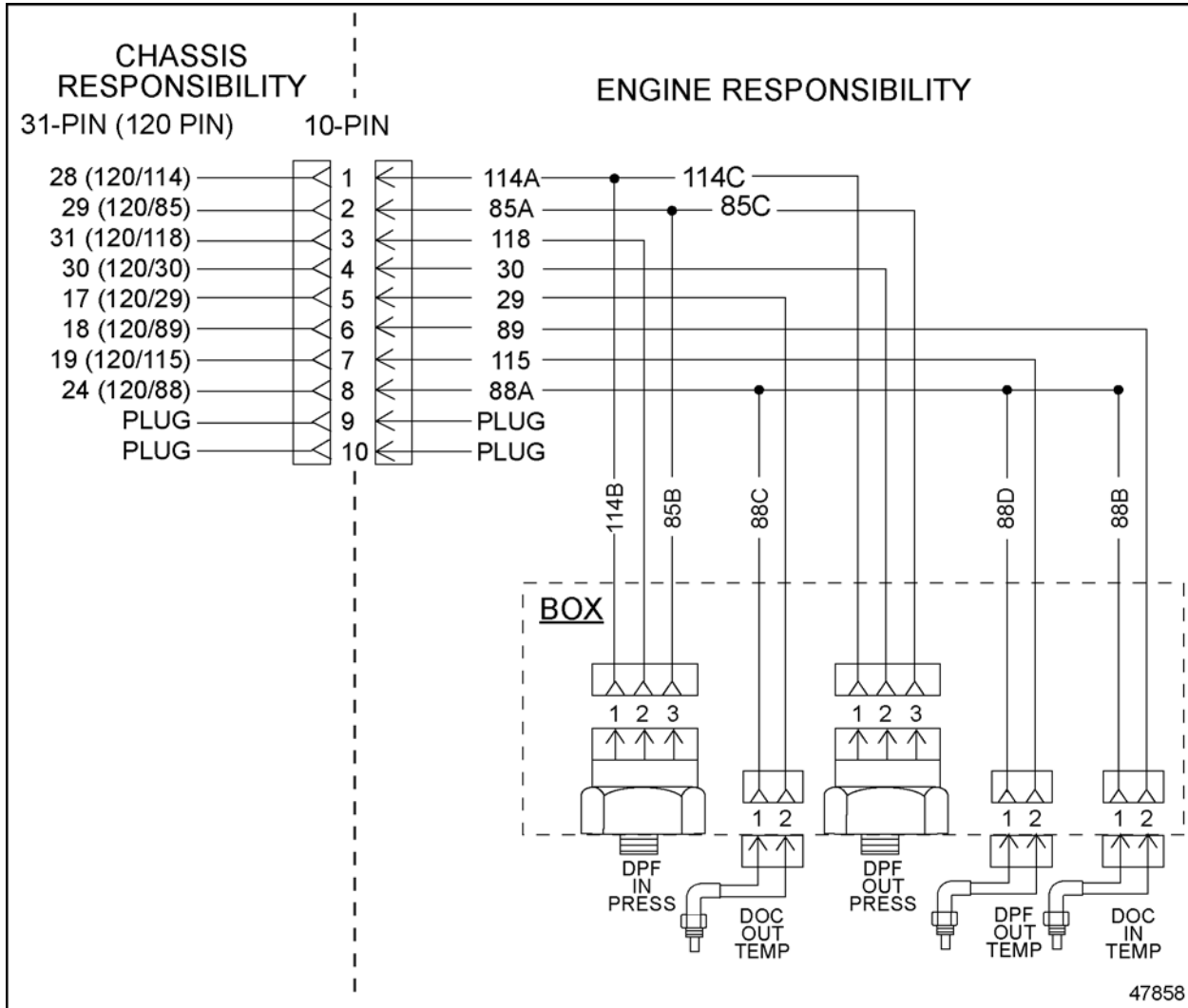

Figure 3 Vertical Aftertreatment Device Wiring Diagram

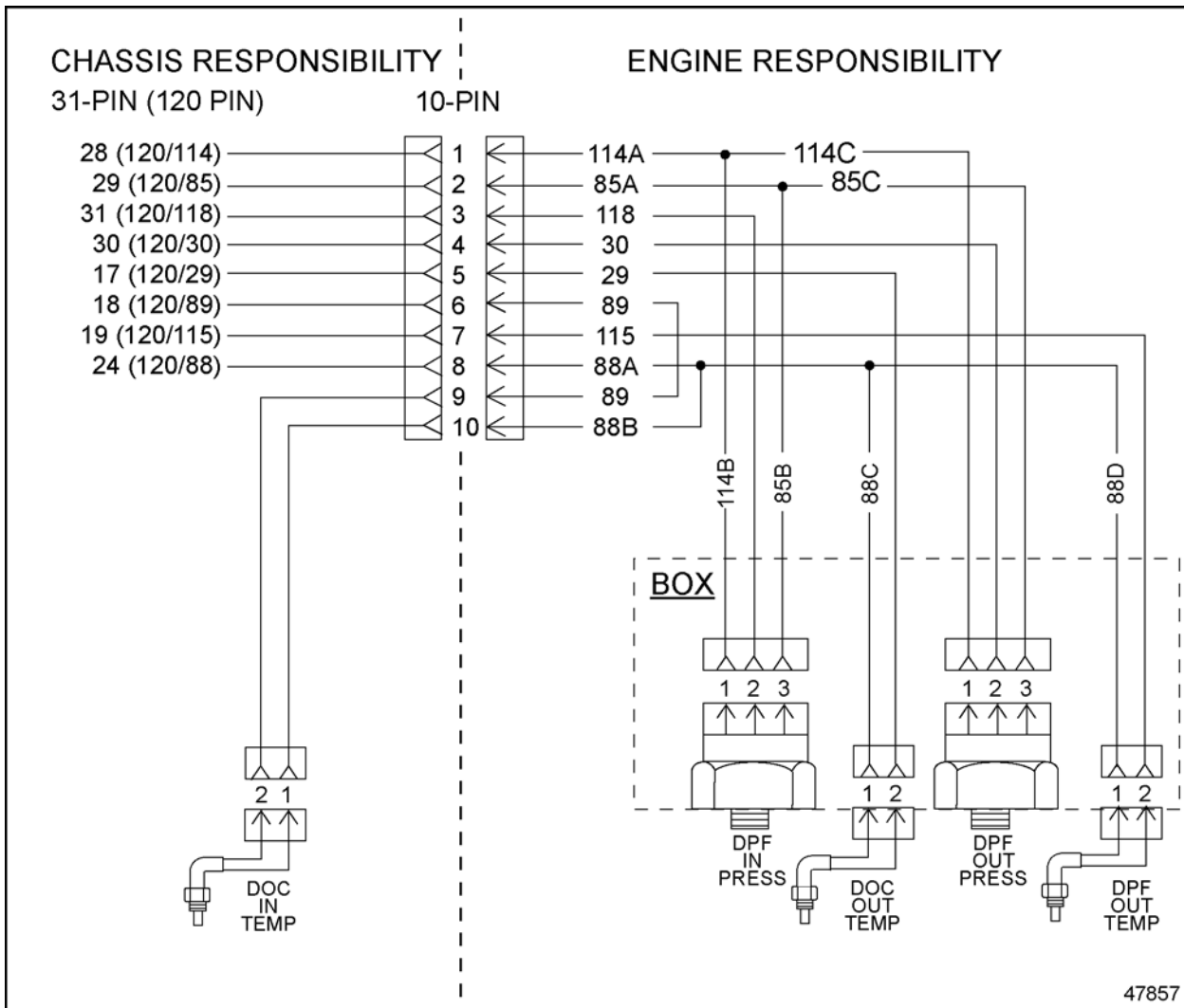

Figure 4 Horizontal Aftertreatment Device Wiring Diagram

CHECK FOR DIESEL OXIDATION CATALYST OUTLET TEMPERATURE SENSOR TEMPERATURE WIRING PROBLEM

Check as follows:

1. Connect DDDL 7.0 or later version.
2. Turn ignition ON (key ON, engine OFF).
3. Check for multiple codes.
 - [a] If fault 3250/3 or 3250/4 is active, troubleshoot this fault first. Verify repairs.
 - [b] If fault 3250/3 or 3250/4 and fault 3250/8 are inactive, go to step 4.

 **CAUTION:**
EXHAUST FUMES

To avoid injury or injury to bystanders from fumes, engine or vehicle fuel system service operations should be performed in a well ventilated area.

4. Start engine.
5. Access the Voltage Service Routine.
6. Select “Start Acquiring”.
7. Wiggle test the harness while looking for abnormal voltage spikes on T_DOC_OUT (pin 29).
 - [a] If a voltage spike is detected, isolate that section of harness and inspect for wiring chaffing, corrosion, improper connections, or physical damage. Repair damage as necessary. Verify repairs.
 - [b] If no voltage spikes are seen, physically check and clean all harness connectors between the DOC Outlet Temperature Sensor and the MCM. Repair damage as necessary. Verify repairs.

SPN 3609/FMI 8

This diagnostic condition indicates the MCM has detected an impossible temperature shift on the DPF Outlet Temperature Sensor. The most likely cause is an intermittent wiring problem. See Figure 5 and Figure 6 for the ATD wiring schematics.

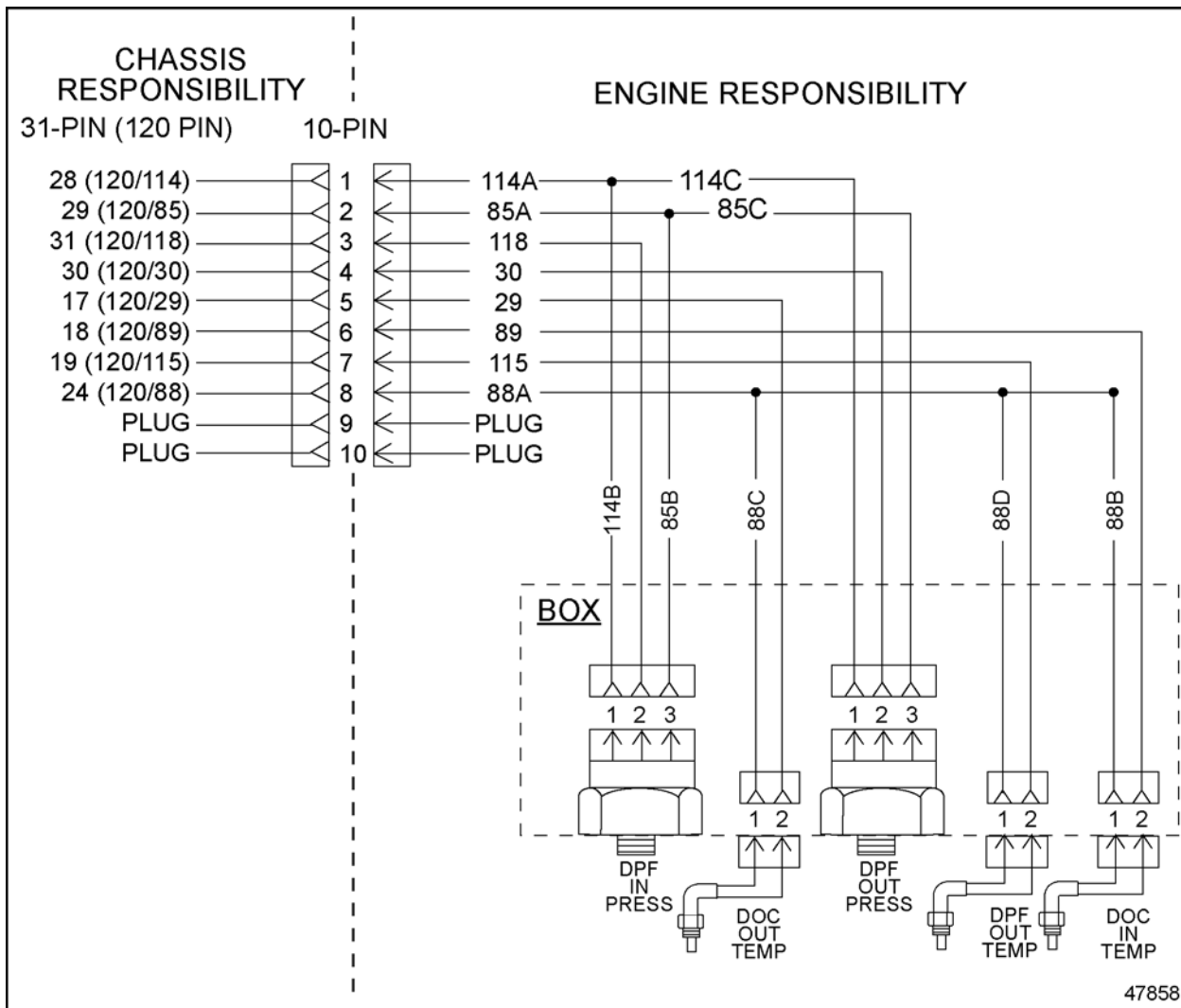

Figure 5 Vertical Aftertreatment Device Wiring Diagram

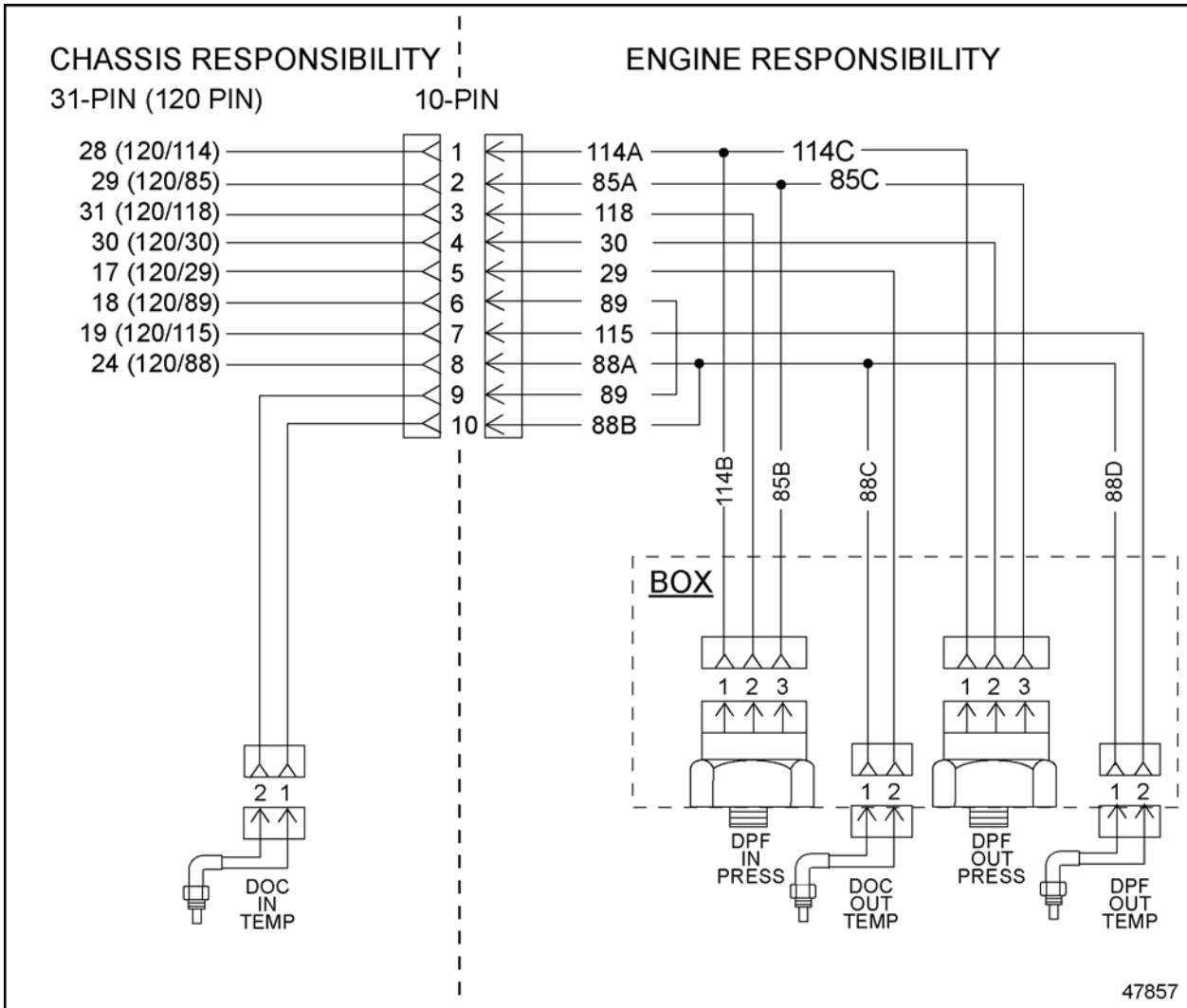

Figure 6 Horizontal Aftertreatment Device Wiring Diagram

CHECK FOR DIESEL PARTICULATE FILTER OUTLET TEMPERATURE SENSOR TEMPERATURE WIRING PROBLEM

Check as follows:

1. Connect DDDL 7.0 or later version.
2. Turn ignition ON (key ON, engine OFF).
3. Check for multiple codes.
 - [a] If fault 3609/3 or 3609/4 is active, troubleshoot this fault first. Verify repairs.
 - [b] If fault 3609/3 or 3609/4 and fault 3609/8 are inactive, go to step 4.

 CAUTION: EXHAUST FUMES
To avoid injury or injury to bystanders from fumes, engine or vehicle fuel system service operations should be performed in a well ventilated area.

4. Start engine.
5. Access the Voltage Service Routine.
6. Select “Start Acquiring”.
7. Wiggle test the harness while looking for abnormal voltage spikes on T_DPF_OUT (pin 115).
 - [a] If a voltage spike is detected, isolate that section of harness and inspect for wiring chaffing, corrosion, improper connections, or physical damage. Repair damage as necessary. Verify repairs.
 - [b] If no voltage spikes are seen, physically check and clean all harness connectors between the DPF Outlet Temperature Sensor and the MCM. Repair damage as necessary. Verify repairs.

ADDITIONAL SERVICE INFORMATION

Additional service information is available in the Detroit Diesel *ATS Technician's Guide*, 7SE63. The next revision to this manual will include the revised information.

DETROIT DIESEL
CORPORATION



13400 Outer Drive, West / Detroit, Michigan 48239-4001
Telephone: 313-592-5000
www.detroitdiesel.com